

GPH250 1000W PANEL HEATER



Product Attributes

- 2 Heat settings
- Adjustable thermostat
- Castor wheels
- Overheat protection
- Wall mountable
- Approximate Size: H 410 x W 460 x D 120mm
- Weight: 3.6kg

Technical Informations

- 900-1000W
- 220-240VAC 50Hz

Admin Informations

- Carton quantity: 1
- Barcode: 9420014231640

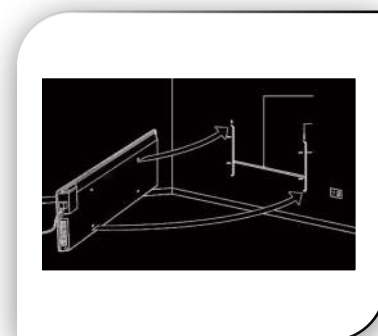

CDB  **GOLDAIR**

New Zealand
PO Box 100-707
North Shore Mail Centre
Auckland 0745
www.goldair.co.nz

Australia
PO Box 574
South Morang
Victoria 3752
www.goldair.com.au