



SIRIUS soft starter S2 63 A, 30 kW/400 V, 40 °C 200-480 V AC, 24 V AC/DC Screw terminals

General technical data		
product brand name		SIRIUS
product feature		
<ul style="list-style-type: none"> integrated bypass contact system thyristors 		Yes Yes
product function		
<ul style="list-style-type: none"> intrinsic device protection motor overload protection evaluation of thermistor motor protection external reset adjustable current limitation inside-delta circuit 		Yes Yes No Yes Yes No
product component motor brake output		No
insulation voltage rated value	V	600
degree of pollution		3, acc. to IEC 60947-4-2
reference code according to EN 61346-2		Q
reference code according to DIN 40719 extended according to IEC 204-2 according to IEC 750		G
Power Electronics		
product designation		Soft starter
operational current		
<ul style="list-style-type: none"> at 40 °C rated value at 50 °C rated value at 60 °C rated value 	A A A	63 58 53
yielded mechanical performance for 3-phase motors		
<ul style="list-style-type: none"> at 230 V <ul style="list-style-type: none"> at standard circuit at 40 °C rated value at 400 V <ul style="list-style-type: none"> at standard circuit at 40 °C rated value 	kW kW	18.5 30
yielded mechanical performance [hp] for 3-phase AC motor at 200/208 V at standard circuit at 50 °C rated value	hp	15
operating frequency rated value	Hz	50 ... 60
relative negative tolerance of the operating frequency	%	-10
relative positive tolerance of the operating frequency	%	10
operating voltage at standard circuit rated value	V	200 ... 480
relative negative tolerance of the operating voltage at standard circuit	%	-15
relative positive tolerance of the operating voltage at standard circuit	%	10
minimum load [%]	%	20

adjustable motor current for motor overload protection minimum rated value	A	26
continuous operating current [% of I _e] at 40 °C	%	115
power loss [W] at operational current at 40 °C during operation typical	W	12
Control circuit/ Control		
type of voltage of the control supply voltage		AC/DC
control supply voltage frequency 1 rated value	Hz	50
control supply voltage frequency 2 rated value	Hz	60
relative negative tolerance of the control supply voltage frequency	%	-10
relative positive tolerance of the control supply voltage frequency	%	10
control supply voltage 1 at AC		
• at 50 Hz rated value	V	24
• at 60 Hz rated value	V	24
relative negative tolerance of the control supply voltage at AC at 50 Hz	%	-20
relative positive tolerance of the control supply voltage at AC at 50 Hz	%	20
relative negative tolerance of the control supply voltage at AC at 60 Hz	%	-20
relative positive tolerance of the control supply voltage at AC at 60 Hz	%	20
control supply voltage 1 at DC rated value	V	24
relative negative tolerance of the control supply voltage at DC	%	-20
relative positive tolerance of the control supply voltage at DC	%	20
display version for fault signal		red
Mechanical data		
size of engine control device		S2
width	mm	55
height	mm	160
depth	mm	170
fastening method		screw and snap-on mounting
mounting position		With additional fan: With vertical mounting surface +/-90° rotatable, with vertical mounting surface +/- 22.5° tiltable to the front and back Without additional fan: With vertical mounting surface +/-10° rotatable, with vertical mounting surface +/- 10° t
required spacing with side-by-side mounting		
• upwards	mm	60
• at the side	mm	30
• downwards	mm	40
wire length maximum	m	300
number of poles for main current circuit		3
Connections/ Terminals		
type of electrical connection		
• for main current circuit		screw-type terminals
• for auxiliary and control circuit		screw-type terminals
number of NC contacts for auxiliary contacts		0
number of NO contacts for auxiliary contacts		2
number of CO contacts for auxiliary contacts		1
type of connectable conductor cross-sections for main contacts for box terminal using the front clamping point		
• solid		2x (1.5 ... 16 mm ²)
• finely stranded with core end processing		0.75 ... 25 mm ²
• stranded		0.75 ... 35 mm ²
type of connectable conductor cross-sections for main contacts for box terminal using the back clamping point		
• solid		2x (1.5 ... 16 mm ²)

<ul style="list-style-type: none"> finely stranded with core end processing stranded 		1.5 ... 25 mm ² 1.5 ... 35 mm ²
type of connectable conductor cross-sections for main contacts for box terminal using both clamping points <ul style="list-style-type: none"> solid finely stranded with core end processing stranded 		2x (1.5 ... 16 mm ²) 2x (1.5 ... 16 mm ²) 2x (1.5 ... 25 mm ²)
type of connectable conductor cross-sections at AWG cables for main contacts for box terminal <ul style="list-style-type: none"> using the back clamping point using the front clamping point using both clamping points 		16 ... 2 18 ... 2 2x (16 ... 2)
type of connectable conductor cross-sections for auxiliary contacts <ul style="list-style-type: none"> solid finely stranded with core end processing 		2x (0.5 ... 2.5 mm ²) 2x (0.5 ... 1.5 mm ²)
type of connectable conductor cross-sections at AWG cables <ul style="list-style-type: none"> for auxiliary contacts for auxiliary contacts finely stranded with core end processing 		2x (20 ... 14) 2x (20 ... 16)

Ambient conditions

installation altitude at height above sea level	m	5 000
environmental category <ul style="list-style-type: none"> during transport according to IEC 60721 during storage according to IEC 60721 during operation according to IEC 60721 		2K2, 2C1, 2S1, 2M2 (max. fall height 0.3 m) 1K6 (only occasional condensation), 1C2 (no salt mist), 1S2 (sand must not get inside the devices), 1M4 3K6 (no formation of ice, no condensation), 3C3 (no salt mist), 3S2 (sand must not get into the devices), 3M6
ambient temperature <ul style="list-style-type: none"> during operation during storage 	°C	-25 ... +60 -40 ... +80
derating temperature	°C	40
protection class IP on the front according to IEC 60529		IP20
touch protection on the front according to IEC 60529		finger-safe, for vertical contact from the front

Certificates/ approvals

General Product Approval	EMC
---------------------------------	------------



[Confirmation](#)



For use in hazardous locations	Declaration of Conformity	Test Certificates	Marine / Shipping
---------------------------------------	----------------------------------	--------------------------	--------------------------



[Special Test Certificate](#)

[Type Test Certificates/Test Report](#)



Marine / Shipping	other	Railway
--------------------------	--------------	----------------



[Confirmation](#)

[Vibration and Shock](#)

[Confirmation](#)

UL/CSA ratings

yielded mechanical performance [hp] for 3-phase AC motor		
	• at 220/230 V	
— at standard circuit at 50 °C rated value	hp	20
• at 460/480 V		
— at standard circuit at 50 °C rated value	hp	40
contact rating of auxiliary contacts according to UL		B300 / R300

Further information

Simulation Tool for Soft Starters (STS)

<https://support.industry.siemens.com/cs/ww/en/view/101494917>

Information- and Downloadcenter (Catalogs, Brochures,...)

<https://www.siemens.com/ic10>

Industry Mall (Online ordering system)

<https://mall.industry.siemens.com/mall/en/en/Catalog/product?mlfb=3RW4037-1BB04>

Cax online generator

<http://support.automation.siemens.com/WW/CAXorder/default.aspx?lang=en&mlfb=3RW4037-1BB04>

Service&Support (Manuals, Certificates, Characteristics, FAQs,...)

<https://support.industry.siemens.com/cs/ww/en/ps/3RW4037-1BB04>

Image database (product images, 2D dimension drawings, 3D models, device circuit diagrams, EPLAN macros, ...)

http://www.automation.siemens.com/bilddb/cax_de.aspx?mlfb=3RW4037-1BB04&lang=en

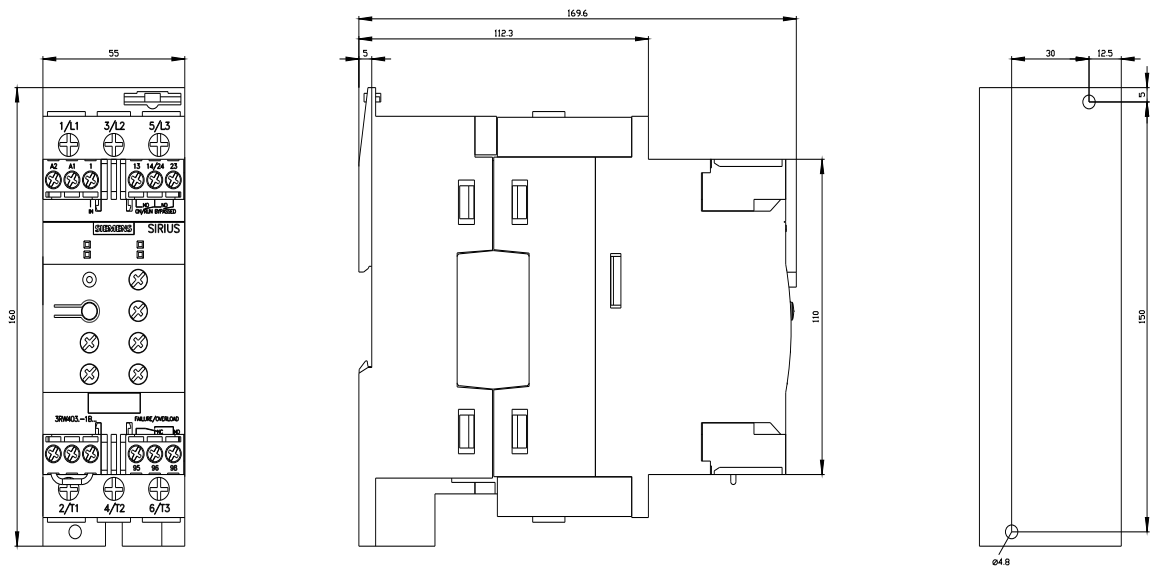

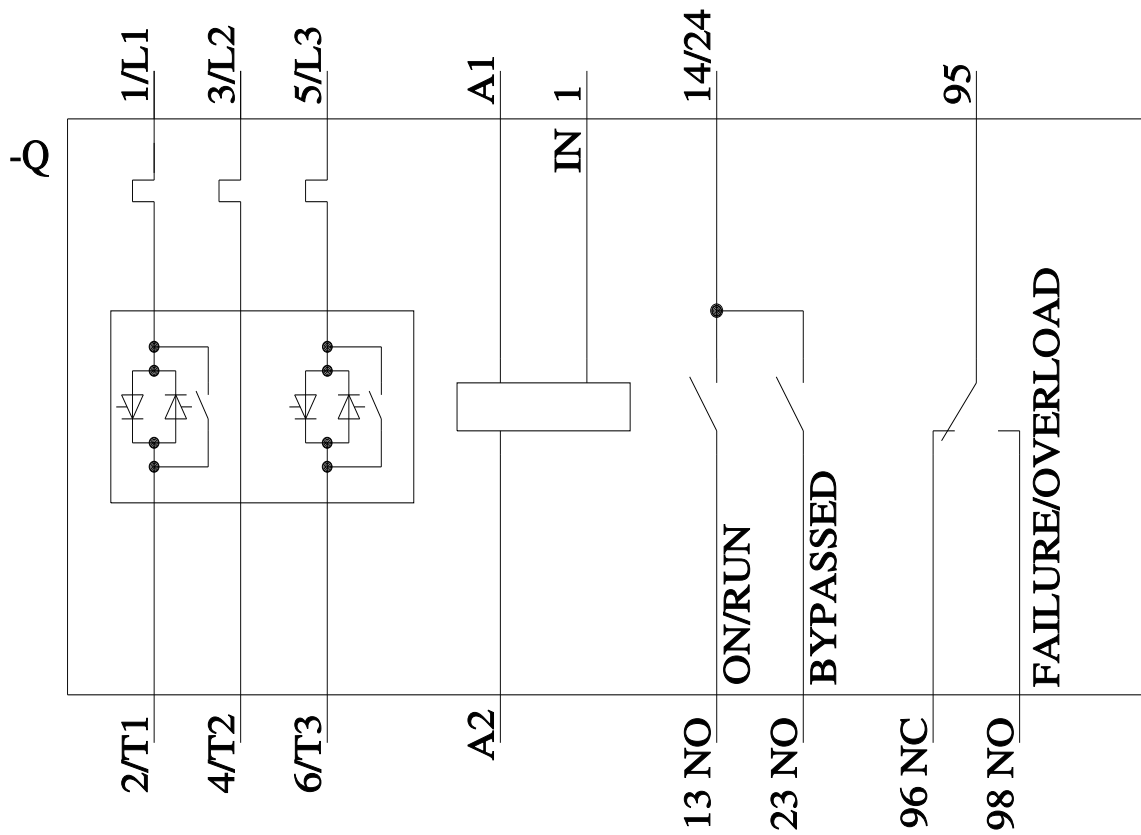

last modified:

1/16/2022 