

Through Roof Fans

INSTALLATION INSTRUCTIONS

Please Note: Junction Box is only supplied with:

FAN0530 / FAN0532 / FAN0534 / FAN0535 / DCT0189 / FAN0740 / FAN0967/FAN1009

CAUTION

- This appliance is not intended for use by persons (including children) with reduced physical, sensory or mental capabilities, or lack of experience and knowledge, unless they have been given supervision or instruction concerning use of the appliance by a person responsible for their safety.
- Children should be supervised to ensure that they do not play with the appliance.
- If any of the supply cords are damaged they must be replaced by the manufacturer, its service agent or similarly qualified persons in order to avoid possible damage to the system.
- Precautions must be taken to avoid the back-flow of gases into the room from the open flue of gas or other fuel-burning appliances.
- Means for disconnection must be incorporated in the fixed wiring in accordance with AS/NZS wiring rules.

ELECTRICAL CONNECTION

Important Note: Junction Box supplied is suitable for internal use and below roof installation. (inside of the building)

Cut the Dektite roof flashing on the 150/160 marking and fit to the rigid duct before commencing. (See separate installation sheet detailing this).

For below roof terminations the motor lead exit hole should be as far down the rigid duct as is practical – allow enough lead to protrude from the duct as is required for termination. After fitting the Dektite, drill an 8mm hole at a suitable point in the rigid duct and fit the supplied rubber grommet. The motor lead can then be passed through the grommet to the outside of the rigid duct.

The assembly can now be placed in position in the roof penetration per the separate instruction sheet – “Installation Instructions for Roof Penetrations”. Once the assembly has been fastened to the roof by the Dektite fastening procedure, the electrical connections can be made. The junction box can be fastened to the rigid duct if necessary.

You may find it more convenient to pull the whole assembly down as far as possible in the Dektite flashing to carry out the terminations. (Fig. 1.) Once completed, the assembly can then be pushed back up through the Dektite. (Ensure that a visual check is made above the roof afterwards to check that the Dektite is sealing correctly around the rigid duct). (Fig. 2.) Once the terminations are completed the rigid duct can then be fastened to a rafter or purlin with the supplied clamp for rigidity. Ducting connections can then be made.



Fig 1

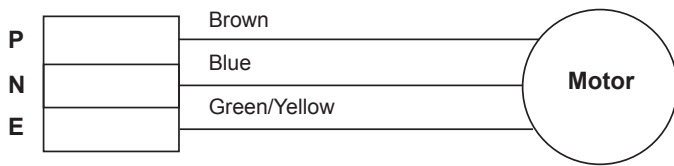

Fig 2

Wiring Connections:

For axial flow induction motor models (no capacitor):

FAN0531/FAN0533/FAN0532/FAN0534/FAN0739/FAN1060/FAN1009/DCT0189



For centrifugal fan models: FAN0529/FAN0530/
FAN0535/FAN0740

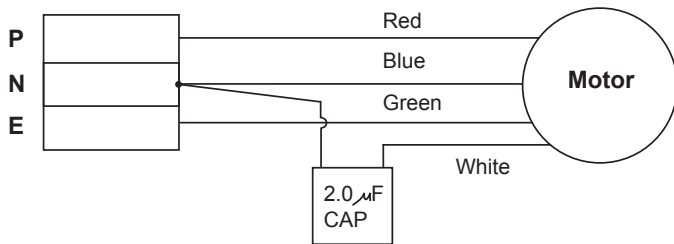

Connect SP3/SP2/SP1 to single phase (P) for High/ Medium/ Low speed control

For FAN0967 model (3 speed)

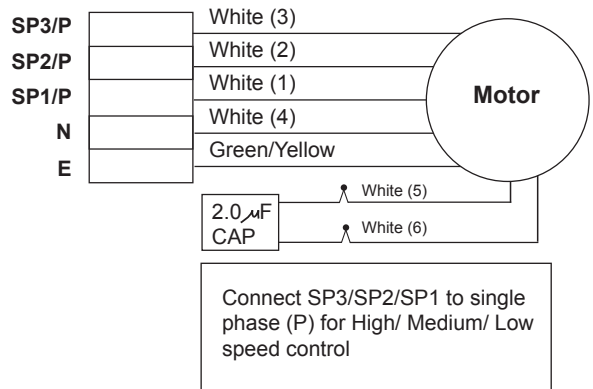

For FAN1002 (3 Speed)

