



USB Charger Module Installation Instructions

692, 695 and 642M USB Charger USB Charger Module 1.2 amp 6 watts

Installation Instructions for Cat. 692, 695 and 642M USB chargers

Safety

DANGER

HAZARD OF ELECTRIC SHOCK OR ARC FLASH

- This equipment must only be installed and serviced by appropriately qualified and/or licensed electrical personnel.
- Isolate the electrical supply before doing any work on this equipment.
- Ensure that the product has been correctly installed and tested for safe operation before reconnecting the electrical supply.
- The supply circuit must be turned off, locked and tagged before wiring the USB charger.
- The fly leads from the 642MUSB are labelled as Active and Neutral. During installation they must be wired to the correct line from the Mains supply.
- Ensure when assembling USB conductors that the wiring is connected to the correct terminals.
- The device needs to be located within a wall cavity and clipped into a mounting plate to adhere to safety standards.
- After wiring, wrap the connector block with insulating tape.
- The USB Charger must be connected to an easily accessible disconnect device, RCD or MCB.

Failure to follow these instructions will result in death or serious injury

NOTE

Severe penalties apply if electrical equipment is not installed and serviced by appropriately qualified and/ or licensed electrical personnel.

A qualified person is one who has skills and knowledge related to the construction, installation and operation of electrical equipment and has received safety training to recognise and avoid the hazards involved.

Specifications

Maximum Input Current	80mA
Output Voltage over 500mA	>2V
Output Voltage Standby	4.75V - 5.25V
Output Voltage up to 500mA	4.75V - 5.25V
Maximum Output Current	5V = 1.2A
Standby Power	70mW
Supply Voltage	230-240V a.c
Input frequency	50Hz
Standards	IEC 60950-1, AS/NZS 3100, CISPR 22, AS/NZS 4665, SB-IF Battery Charging Specification 1.2 (BC 1.2)

Cable compensation capabilities, helping to achieve maximum charge rates for devices
Surge, overcurrent and over temperature protection when thermal and electrical tolerances are exceeded
Non resettable fuse on the active line
Single polarised input connection
Fly leads are single insulated wires

Warranty Statement

1. The benefits conferred herein are in addition to, and in no way shall be deemed to derogate; either expressly or by implication, any or all other rights and remedies in respect to the Schneider Electric product, which the consumer has under the Consumer Guarantees Act or any other similar laws.
2. The warrantor is Schneider Electric.
3. This Schneider Electric product is guaranteed against faulty workmanship and materials for a period of twelve (12) months from the date of installation.
4. Schneider Electric reserves the right, at its discretion, to either repair free of parts and labour charges, replace or offer refund in respect to any article found to be faulty due to materials, parts or workmanship.
5. This warranty is expressly subject to the Schneider Electric product being installed, wired, tested, operated and used in accordance with the manufacturer's instructions.
6. All costs of a claim shall be met by Schneider Electric, however should the product that is the subject of the claim be found to be in good working order all such costs shall be met by the claimant.
7. When making a claim the consumer shall forward the Schneider Electric product to the nearest office of Schneider Electric with adequate particulars of the defect within 28 days of the fault occurring. The product should be returned securely packed, complete with details of the date and place of purchase, description of load, and circumstances of malfunction.

Install Instructions

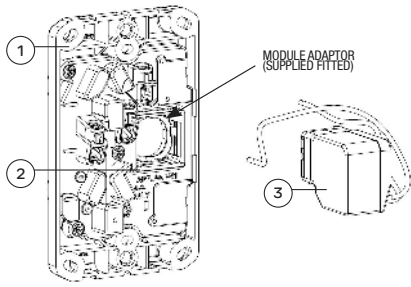

- 1 692X
- 2 619M clipped into plate
- 3 USB charger module

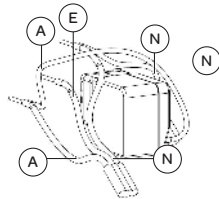

Twisted wires together

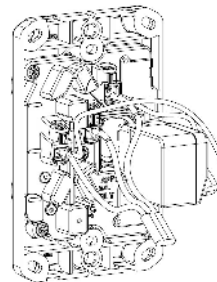

Terminate wires
Into socket and tighten
screws

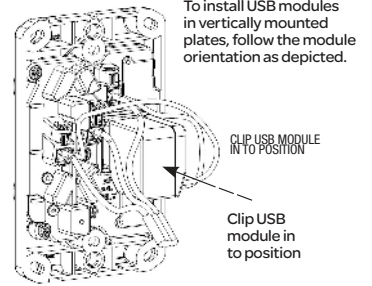

Clip USB module into
plate

To install USB modules
in vertically mounted
plates, follow the module
orientation as depicted.

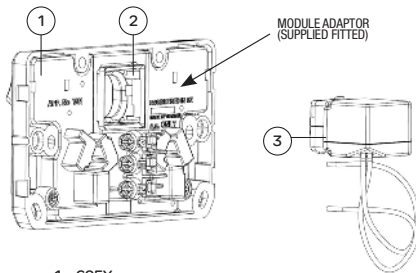

- 1 695X
- 2 619M clipped into plate
- 3 USB charger module

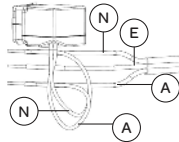

Twisted wires together

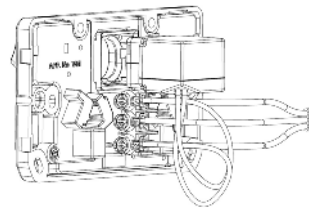

Terminate wires
Into socket and tighten
screws

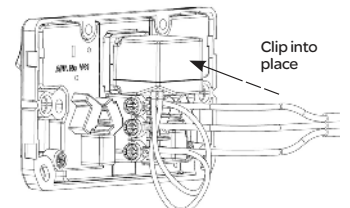

Clip USB module into
plate

Clip into
place

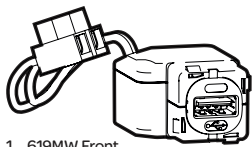

- 1 619MW Front
- 2 619MW Back
- 3 642MUSBC Module

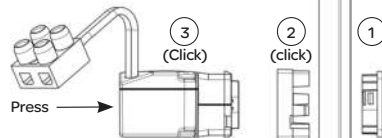
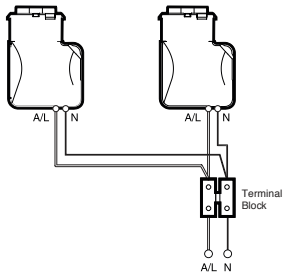

- 1 Place The front clip into any PDL 500 /600 series aperture
 - 2 Place the back clip onto the back for the plate and clip together
- Note when these two parts are clipped together they can not be taken apart.

When the USB charger has been terminated clip the charger into the back of the subplate and mount product to the wall

REMOVING

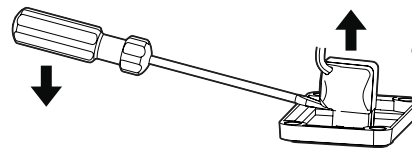

Pry out slowly
Only use flat screwdriver
(standard) 4mm wide
minimum

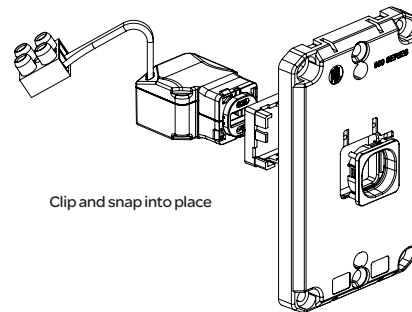

Clip and snap into place

Technical and Sales Support

For assistance with technical problems, contact your nearest Schneider Electric sales representative

Schneider Electric (NZ) Ltd.

38 Business Parade South,
East Tarnaki, Manukau 2013
PO Box 259370, Botany, Manukau 2163
Tel: +64 9 829 0490 Fax: +64 9 829 0491

Customer Care: 0800 652 999
Email: sales@nz.schneider-electric.com
www.schneider-electric.com

