

# Installation and operation manual

## AC MAX

### EU-Smart version



Version: 1.0.2  
Issue date: 2022-02



## Table of Contents

1	Information.....	3
1.1	Copyright.....	3
1.2	Intended use .....	3
1.3	Safety instructions.....	3
1.4	Operator's duty of supervision .....	4
1.5	Model series.....	5
1.6	Product overview.....	6
2	Installation .....	9
2.1	Preparation before start .....	9
2.2	Installation steps .....	11
3	Commissioning .....	22
3.1	Connection setting .....	23
3.2	Login .....	24
3.3	Configuration.....	25
3.4	Edit password.....	28
3.5	Maintenance .....	28
3.6	Forgot password .....	32
4	Operation.....	33
4.1	Start charging.....	33
4.2	Stop charging.....	33
5	LED Indicator.....	33
5.1	Fault events .....	34
5.2	Symbol description.....	34
6	Troubleshooting .....	35
7	Specifications .....	36
8	Cleaning .....	37
9	Warranty .....	37
10	Disposal.....	37

# 1 Information

## 1.1 Copyright

The ownership and all intellectual property rights of this Installation and Operation Manual (this “Manual”), including but not limited to the content, data and figures contained herein are vested by Delta Electronics, Inc. (“DELTA”). The Manual can only be applied to operation or use of the device. Any disposition, duplication, dissemination, reproduction, modification, translation, extraction or any other usage to the Manual is prohibited without obtaining DELTA’s prior written permission. As the product will be developed and improved continuously, DELTA may modify or update the Manual from time to time without any notice. DELTA disclaims any kinds or forms of warranty, guarantee or undertaking, either expressly or implicitly, including but not limited to the completeness, accuracy, non-infringement, merchantability or fitness for particular purpose or usage. Copyright © 2021 Delta Electronics, Inc. All Rights Reserved.

## 1.2 Intended use

The device is developed, manufactured, tested and documented according to the safety standards. If you comply with the instructions and safety instructions described for its intended use, the product normally will not pose any danger in terms of property damage or to the health of people. The instructions contained in this manual shall follow to the letter. Otherwise, sources of danger may be produced or safety equipment may be rendered inoperable.

This device may only be used to charge Battery Electric Vehicle or Plug-in Hybrid Electric Vehicle in accordance with the following regulations:

- Mode 3 charging according to IEC 61851-1 for electric vehicles with non-gas discharged batteries.
- Use with plugs and sockets according to IEC 62196.

In addition, the following conditions apply for intended use:

- The device is exclusively for stationary installation.
- The device is designed for installation on a wall or pedestal.
- The device can be used for indoors and outdoors.

The following uses are considered as not intended:

- The charging of electric vehicles with gassing batteries is not permitted.

## 1.3 Safety instructions

Before installing, commissioning, and operating of the EVSE, review this manual carefully and consult with licensed contractors, licensed electricians and installation experts to ensure compliance with local building practices, climate conditions, safety standards, and state and local codes. DELTA is not responsible for damage caused by failure to follow the safety instructions and work instructions in this manual.



### **DANGER**



### **Risk of electric shock**

Dangerous voltages and currents can occur during operation of the EVSE. Therefore, before carrying out any work on the EVSE, take the following protective measures:

- Disconnect all electrical power prior to installing the EVSE. Failure to do so may result in electric shock, physical injury or damage to the electrical system and charging unit.
- Do not remove circuit protective devices or any other component until all electrical power is disconnected.
- Secure the working area against access by unauthorized persons.

- The EVSE must be connected to a grounded, metal, permanent wiring system or an equipment grounding conductor must be run with the circuit conductors and connected to the equipment grounding terminal or lead on the EVSE.
- Use a measuring instrument to check that there is no voltage.
- Use appropriate protection when connecting to the main power distribution cable.



## DANGER



### Risk of electric shock

Dangerous voltages and currents can occur when operating the EVSE.

- Do not use the device to charge or supply other devices.
- Do not touch the contact pins of the charging plug when operating.
- Do not use adapters, conversion adapters or cord extension sets with the EVSE.
- Do not use this EVSE if the flexible power cord or charging cable is frayed, the insulation is broken, or the device shows signs of damage.



## WARNING

- Close the charging plug with the protective cap when not in use.
- Damaged cables may only be replaced by electricians.
- Do not use this EVSE if the enclosure or the vehicle connector is broken, cracked, open, or shows any signs of damage.
- Only pull the charging cable out of the charging socket by the charging plug.



## CAUTION



### Risk of tripping

People can trip over cables lying around.

- ▶ Always hang the charging cable in the holder supplied with the EVSE after use.

- A device using pressure connectors for field wiring connections must be supplied with instructions that specify a range or nominal value of the tightening torque to be applied to the terminal screws of the connectors.
- Any repair work as well as the replacement of components on the EVSE may only be carried out by DELTA. Otherwise the warranty will become void.
- Damaged or illegible safety labels must be replaced.
- The EVSE can only be installed by licensed contractors, or licensed electricians in accordance with all applicable state, local and national electrical codes and standards in a location with non-restricted access.
- To ensure the ingress protection degree IP55, seal all external connections adequately. Seal unused connections with the caps provided.
- Warning notices, warning symbols and other markings attached to the EVSE by DELTA must not be removed.





## 1.4 Operator's duty of supervision

- As the operator of the EVSE, you are responsible for the safety of the users and its proper use.
- As the operator of the EVSE, you are responsible for the safety of particularly vulnerable persons, especially children. Ensure that such persons maintain a sufficient safety distance from the EVSE and the charging cable.
- Consider the emergency routes at the installation site.
- Do not install the device at potentially explosive atmosphere areas (Ex areas).

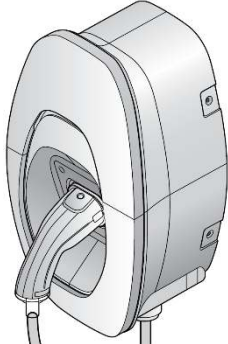
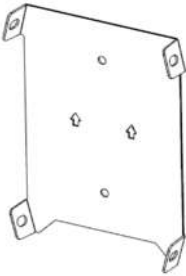
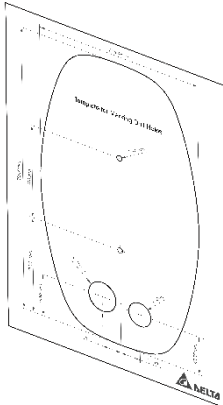

1.6 Product overview

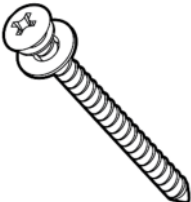
1.6.1 Scope of delivery

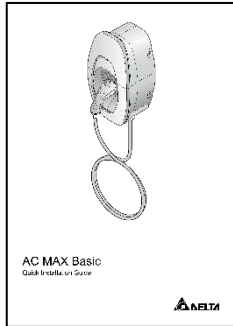
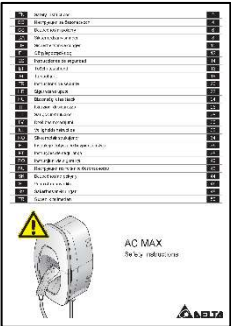
Part	Description	Part	Description
EVSE*	 <p>1x</p>	Mounting bracket	 <p>1x</p>
Template	 <p>1x</p>	Torx T30 mounting bolts	 <p>4x</p>
No. 8 wood screws	 <p>2x</p>	1/4 inch expansion bolts	 <p>2x</p>
Quick installation guide	 <p>1x</p>	Safety instructions	 <p>1x</p>

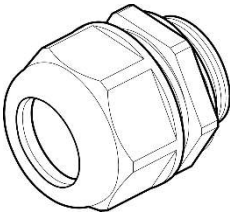
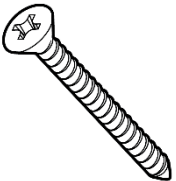
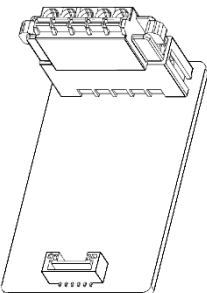
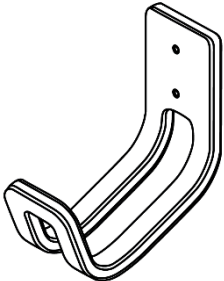
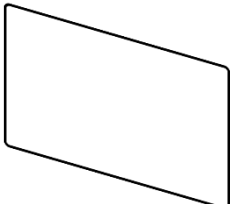
Part	Description	Part	Description
Cable gland	 1x	wood screws	 2x
Control board	 1x	Cable holder* (For plug version only)	 1x
RFID	 2x		

\*Depends on model configuration

## 1.6.2 Recommended tools

The following tools are recommended for the installation of product:

Part	Description
Electro drill	Used for masonry walls
Pencil	
Spirit level	
Terminal crimper	Crimping input wire
Torque wrench	
Torque screwdriver (cross)	Securing mounting bracket to masonry walls or stand
Torque screwdriver (slotted)	Securing mounting bracket to masonry walls or stand
Torx T20 screwdriver	Securing front cover and middle cover
Torx T30 screwdriver	Securing mounting bracket

### 1.6.3 Installer-supplied components

Installers may prepare the following parts:

1. Conduit of appropriate size or cable gland (M32) for input power wires to ensure the water resistance.
2. DIN 46228-4 Cord end terminal:

Please use the cord end terminal for split conductors while installation.

Current	16 A	32 A
Pin length	18 mm	18 mm
Wire range	4 mm <sup>2</sup>	10 mm <sup>2</sup>

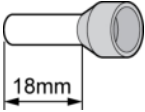

3. Upstream breakers:

To reduce the risk of fire, only connect to a circuit with circuit breaker conforming to IEC 60898-1.

Model	Circuit breaker specification
EIAW-E7K	40A min., 230V min., 2 poles, Type B
EIAW-E11K	20A min., 400V min., 4 poles, Type B
EIAW-E22K	40A min., 400V min., 4 poles, Type B

4. SIM card:

SIM card	Width	Height	Depth	4G support band
Micro SIM	15 mm	12 mm	0.76 mm	Band 1, Band 3, Band 7, Band 8, Band 20

5. Ethernet cable:

Part	Specification
Connector	Modular registered jack 45 (RJ45)
Cable	Category 5 (Cat 5), 10/100 Mbps



## 1.6.4 Overview of components

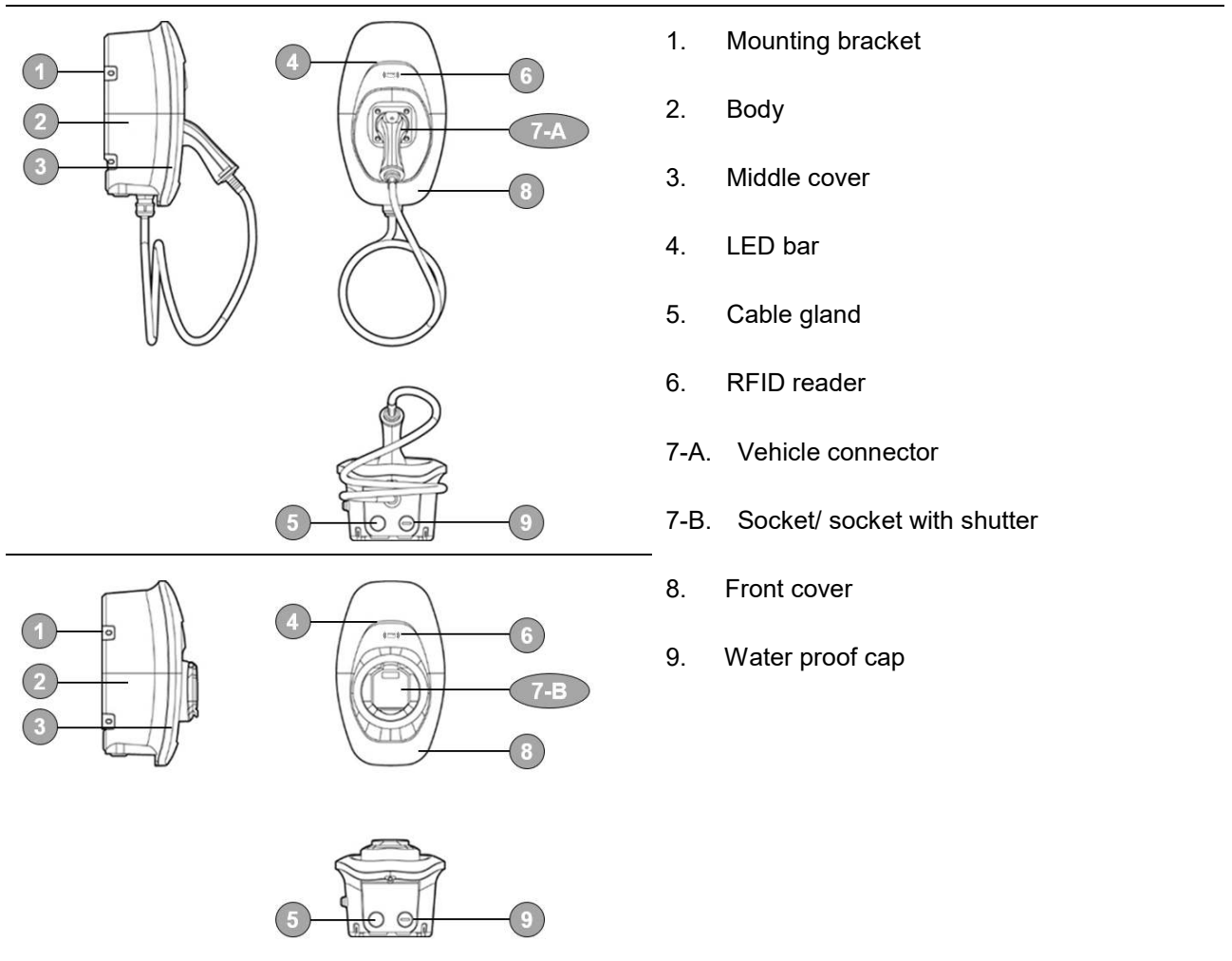

## 2 Installation

Before you start, please read the following instructions:

### 2.1 Preparation before start

#### 2.1.1 Installation site selection

AC MAX can be installed in both indoor and outdoor environments. It is necessary to consider the installation conditions and protection at the site:

- Follow local electrical regulation and installation standards.
- Consider the emergency routes at the installation site.
- Do not install the device at potentially explosive atmosphere areas (Ex areas).

#### 2.1.2 Recommended installation positions

When considering installation positions, make sure EV can be easily connected with EVSE and have enough space for maintenance.

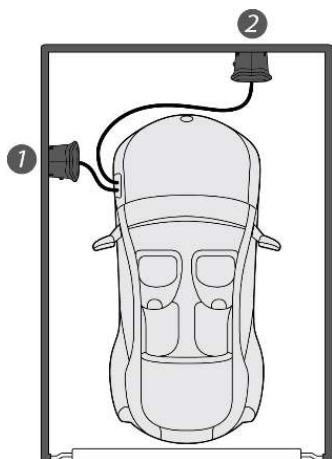

- 1. Recommended position
- 2. Alternative position

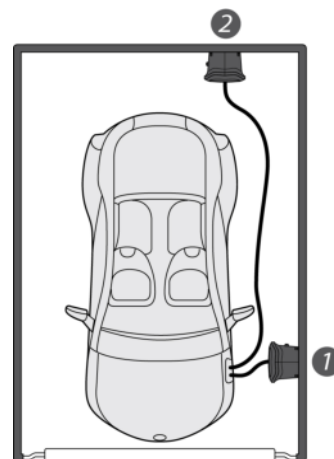

### 2.1.3 Recommended installation space

Installers shall follow applicable accessibility requirements for the mounting position. The EVSE shall be mounted at a height between 800 mm (31.5 inches) and 1200 mm (47.2 inches) above ground.

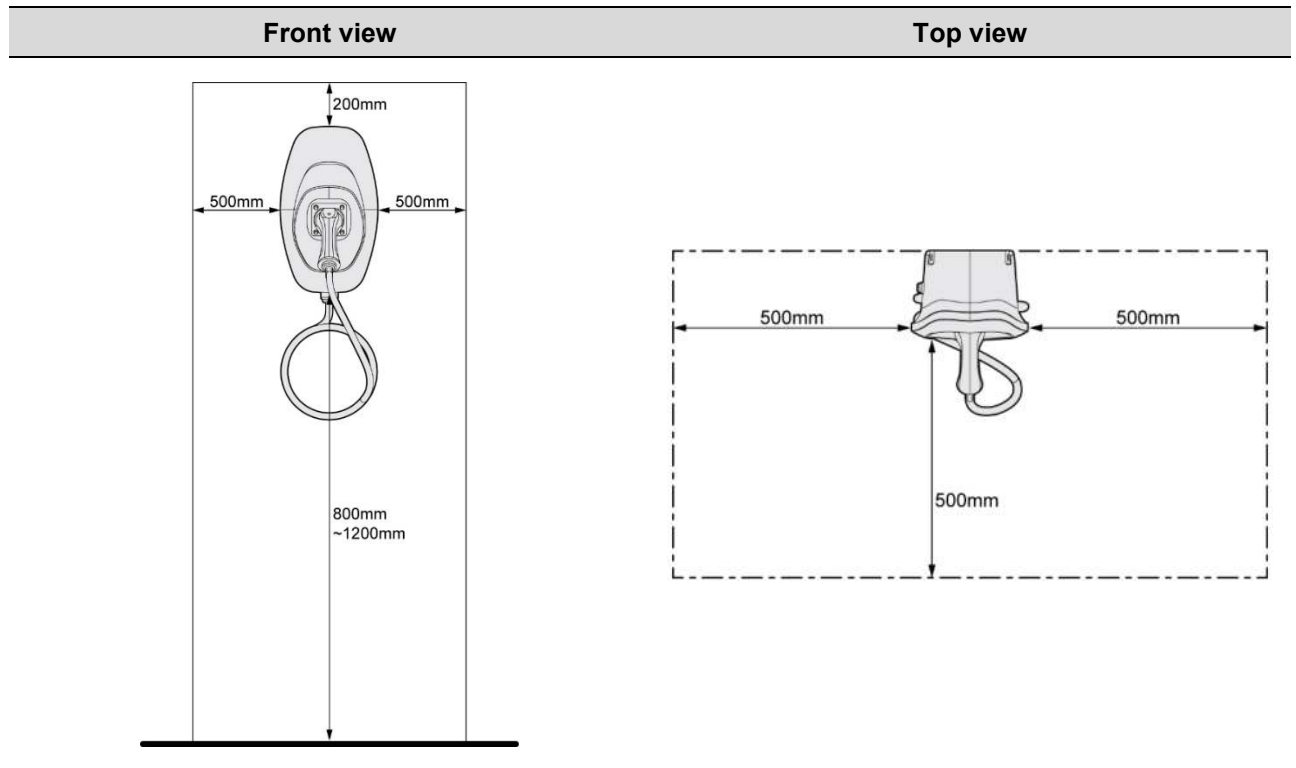

## 2.2 Installation steps

### 2.2.1 Remove front cover and middle cover

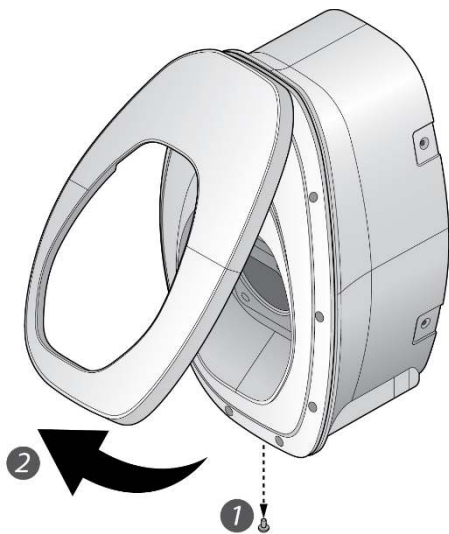

1. Remove the screw located at the bottom of front cover by using a Torx T20 screwdriver.
2. Pull the front cover upward to separate from the EVSE.

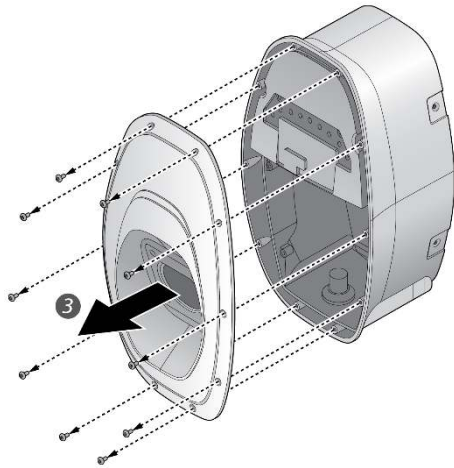

3. Remove the screw located at the middle cover by using a Torx T20 screwdriver.
4. Remove the middle cover.

### 2.2.2 (Optional) insert SIM card for cellular function

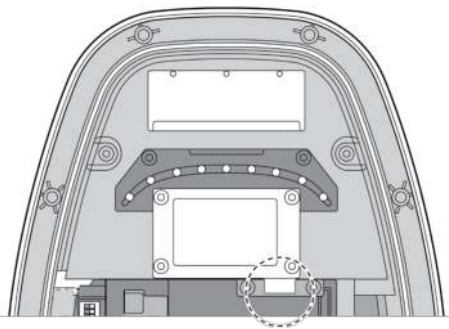

Insert the SIM card into the socket and ensure the connection is well connected.

### 2.2.3 Mark drill holes

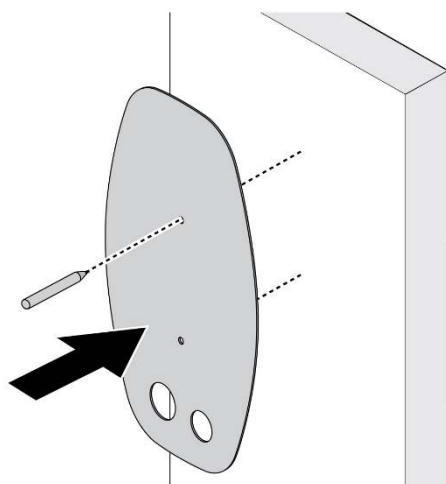

The EVSE is a stationary wall-mounted equipment. Using the template to mark the screw locations for the mounting bracket and cable holder (optional).

## 2.2.4 Secure mounting bracket

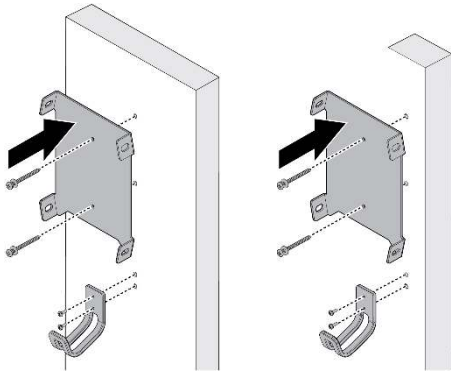

1. The cable holder is optional and depicted in the figure for demonstration purposes. The following are recommended bolt types:

- Masonry walls: 1/4" expansion bolts.
- Finished walls supported by wood studs: #8 wood screws of 2" or above screw length.

Torque: 8.8 N·m (78 lb·in)

Torque: 3 N·m (26 lb·in)

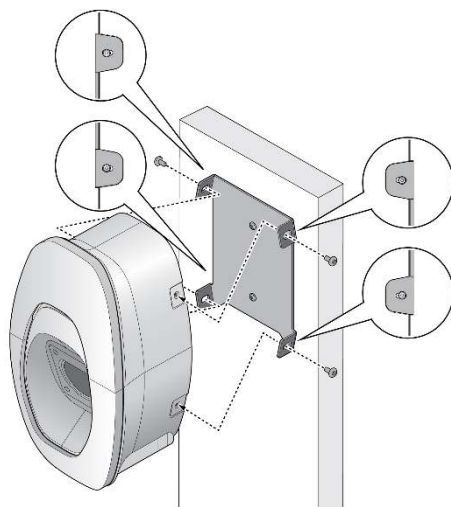

2. Align the EVSE with the screw holes on the mounting bracket.

3. Secure the EVSE on the mounting bracket with the supplied Torx T30 screws.

Torque: 1.5 N·m (13 lb·in)

## 2.2.5 Configure dip switches

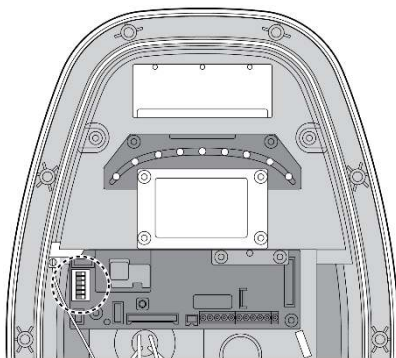

Configure the dip switches with following steps

### 2.2.5.1 Phase unbalance protection

Choose the pin 1 to enable or disable the phase unbalance protection. When the function enabled, the protection will limit the phase unbalance to 15 A.

Configuration	Function	Configuration	Function
	Disable (Default)		Enable

### 2.2.5.2 Authorization mode

Choose the pin 2 to configure the authorization mode for bluetooth availability.

Configuration	Function	Configuration	Function
	Not available		Bluetooth* (Default)

\*Bluetooth connection is reserved for commissioning purpose.

### 2.2.5.3 Grounding system

Choose the pin 3 to configure the grounding system for TT/TN or IT system.

Configuration	Function	Configuration	Function
	TT/TN (Default)		IT

### 2.2.5.4 Maximum current setting

Choose the pin 4-6 to configure the maximum output current ratings.

Configuration	Max. Current Ratings	Configuration	Max. Current Ratings
	6 A (Default)		16 A
	8 A		20 A*
	10 A		24 A*
	12 A		32 A*

\*Depends on model configuration

## 2.2.6 Connect input wire

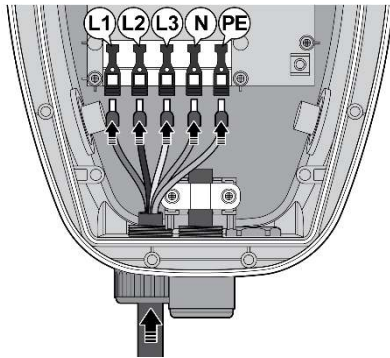

1. Install the copper wire as described. The section of copper wire connected to terminal shall be reserved enough tolerance to prevent any tension or stress from the external force.

Note: Copper wire type: 10 mm<sup>2</sup>, 70°C.

2. Insert the input wire into the terminal accordingly. The cord end terminal shall be inserted to the end without any deviation.

Note: Bottom-fed/rear-fed is available for indoor/outdoor installation with cable gland.

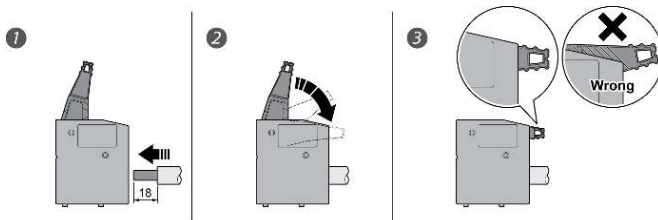

3. Make sure the terminal block is secured correctly.

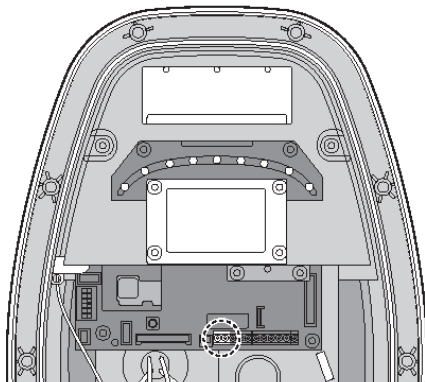

### **Dry contact**

Use appropriate wires (0.75 mm<sup>2</sup>) and connect each of them to the correct terminal connector for dry contact connections shown on wiring schemes (Left 1: NO, Left 2: COM).

Note:

The product provides a closing signal when unable to close the output. There are breaker types that trip to stop output when a closing signal is accepted. It is mandatory requirement for Netherland and Italy.



### 2.2.6.1 Wiring diagram

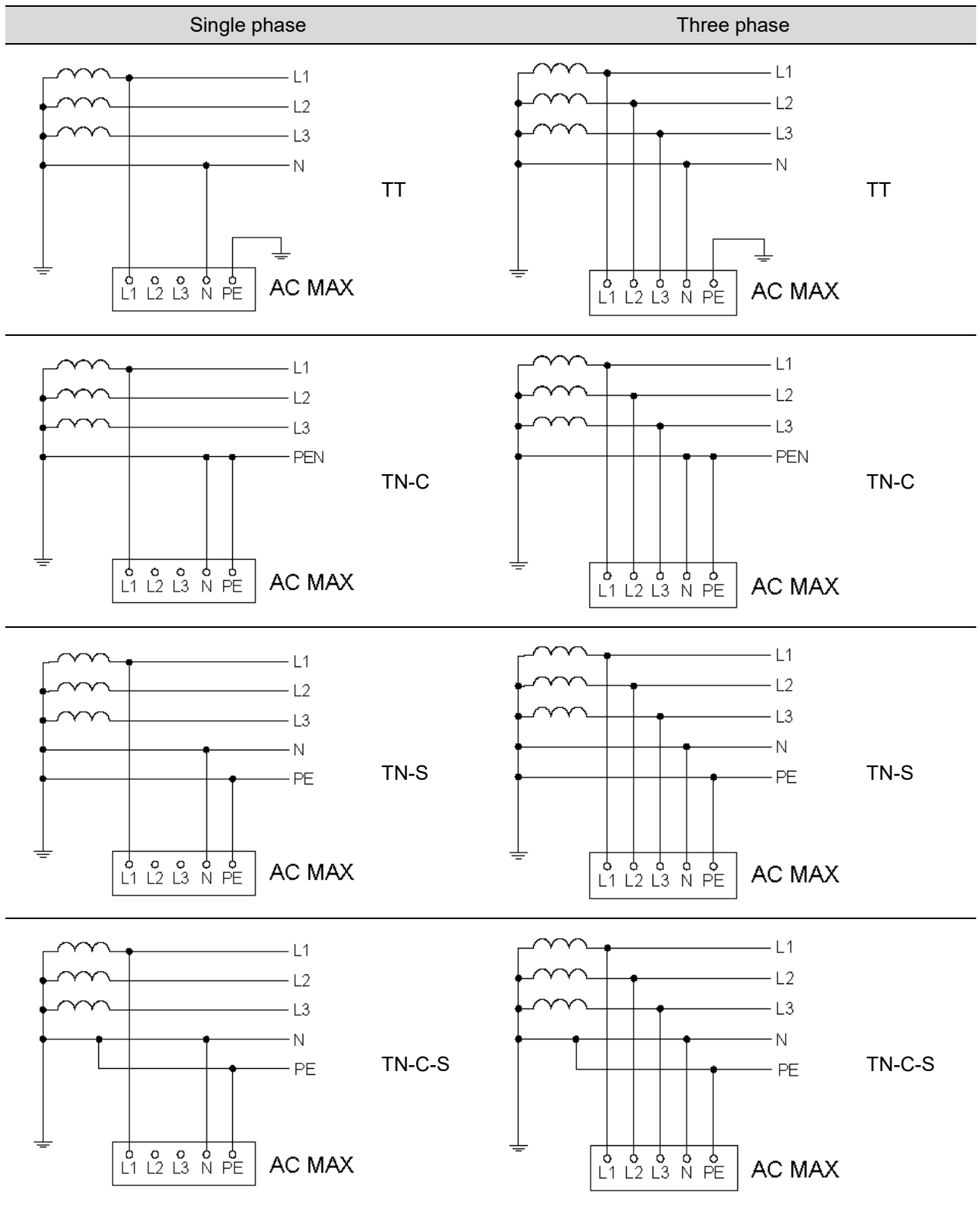

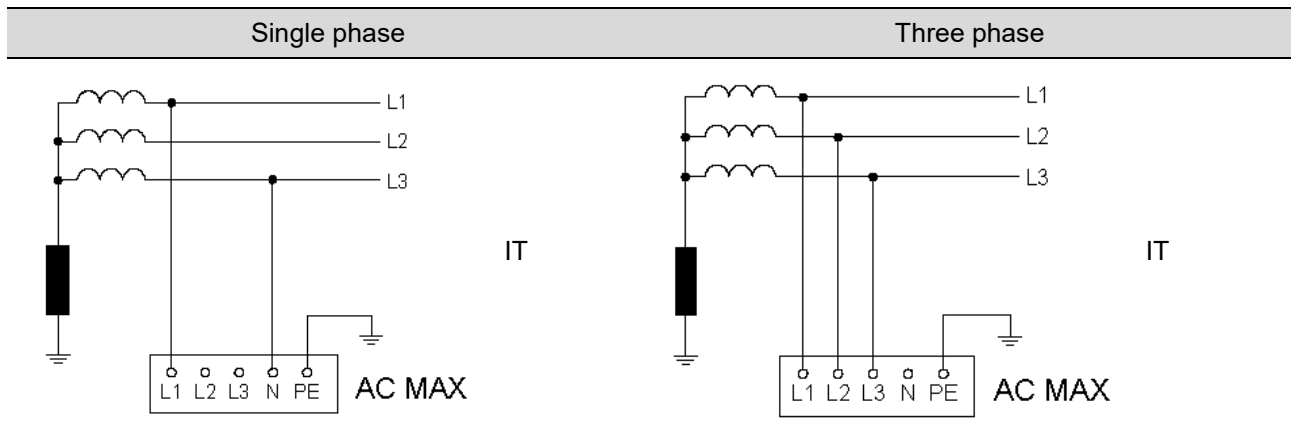

Note: To fulfill requirements for electrical installations in UK, the following shall be observed.

1. When installed in a TN systems, the supplying circuit shall not include a PEN conductor (combined protective and neutral) .
2. If the power grid belongs to TN-C-S system, the charger needs to be grounded separately to TT system. A PME earthing facility shall not be used as the means for the protective conductor contact of a charging point located outdoors.

Note: To fulfill requirements for electrical installations in Singapore, the following shall be observed.

1. Emergency switching (e.g. emergency button) shall be installed to isolate the a.c. electricity supply (mains) from the EV charging station in case of risk of electric shock, fire or explosion.

## 2.2.7 (Optional) active power control

Users can control the EVSE with external components (e.g. a ripple control receiver from the power supplier, a domestic controller, a time switch, a combination lock, a photovoltaic system, etc.).

Note:

1. Ensure that hazardous voltages are isolated safely.
2. The application is taken into consideration for that charging station with a rated power > 12 kVA shall be equipped with control equipment for network integration via an interruptibility by the network operator in Germany.

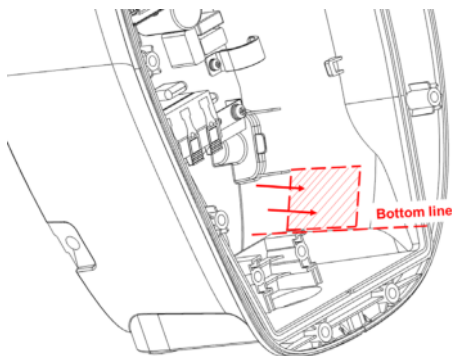

1. Based on the bottom line, attach the control board to the inner surface of EVSE.

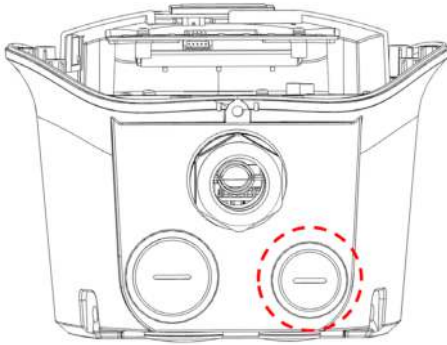

2. Remove the water proof cap and pass through the signal cable with appropriate conduit or cable gland.

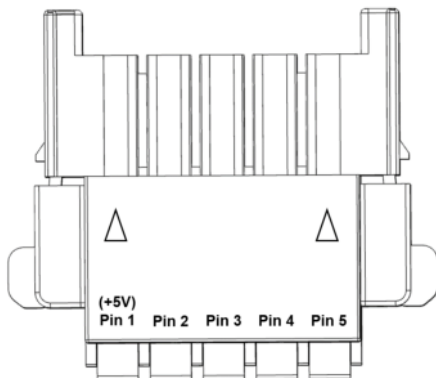

3. Connect the signal cable according to pin definition (2.2.7.1) and must connect to the Pin 1 (+5V).

Note: suggested wire of signal cable: 1.5 mm<sup>2</sup>.

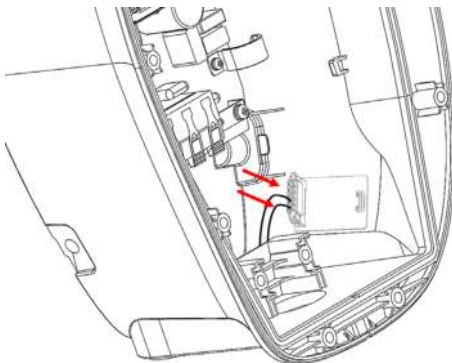

4. Assemble the connector



5. Connect the control board

### 2.2.7.1 Pin definition

User can connect the external component with signal cable based on following configuration. The output power will be adjusted by the following pin definition once the grid power is limited by network operator. The power limitation is based on rated output power configured by dip switches ( 2.2.5.4).

#### 2.2.7.1.1 Configuration A

Connect the signal cable with Pin 1 and Pin 5 as below:

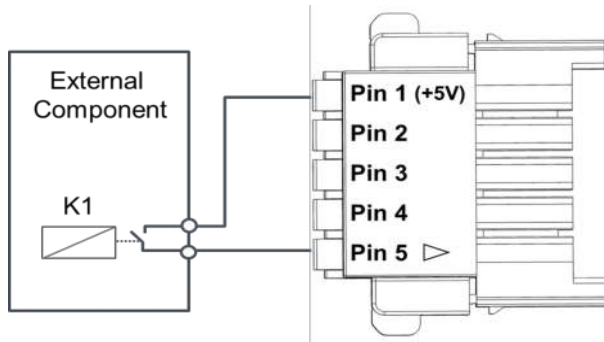

Pin 2	Pin 3	Pin 4	Pin 5	Power limitation
Low	Low	Low	Low	Output 100% power
Low	Low	Low	High	Stop charging

#### 2.2.7.1.2 Configuration B

Connect the signal cable with Pin 1 to Pin 5 as below:

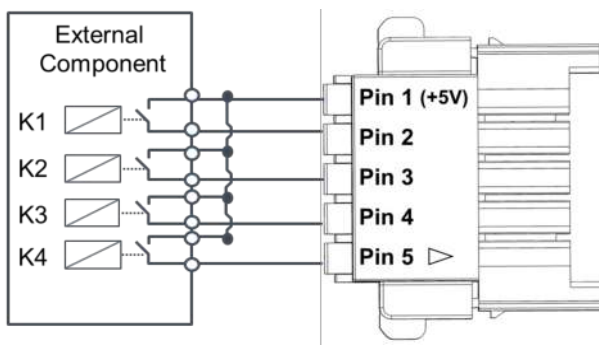

Pin 2	Pin 3	Pin 4	Pin 5	Power limitation
Low	Low	Low	Low	Output 100% power
High	Low	Low	Low	Output 87.5% power
Low	High	Low	Low	Output 75% power
High	High	Low	Low	Output 62.5% power
Low	Low	High	Low	Output 50% power
High	Low	High	Low	Output 37.5% power
Low	High	High	Low	Output 25% power
High	High	High	Low	Output 12.5% power
Low	Low	Low	High	Stop charging

### 2.2.8 (Optional) connect RJ45 port for Ethernet function

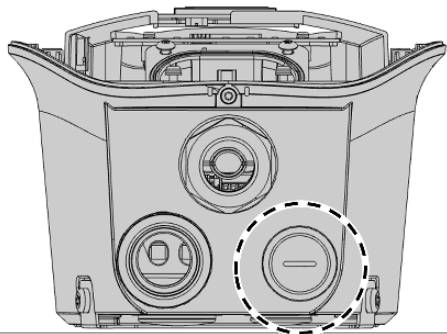

1. Remove the water proof cap and pass through the Ethernet cable with appropriate conduit or cable gland.

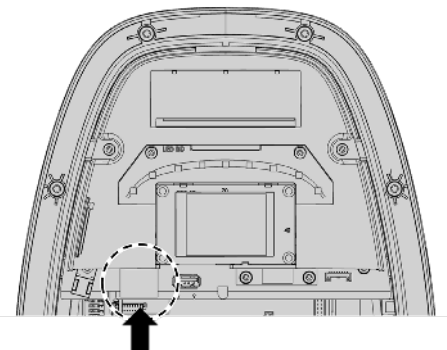

2. Connect the Ethernet cable into the RJ45 port.

## 2.2.9 Secure middle cover and front cover

---

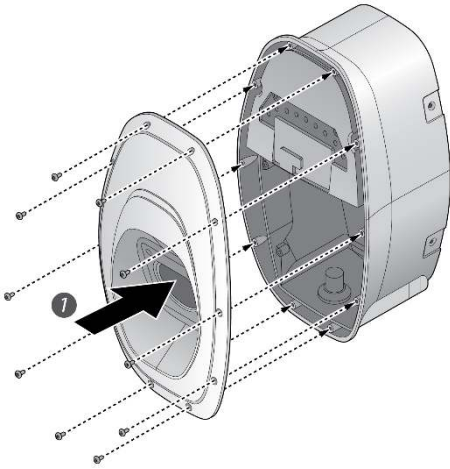

1. Recover the middle cover on the EVSE and secure the middle cover by using Torx T20 screwdriver.

Torque: 1.2 N·m (10.5 lb·in)

Note: rubber sealing shall be put on the appropriate position before recovery.

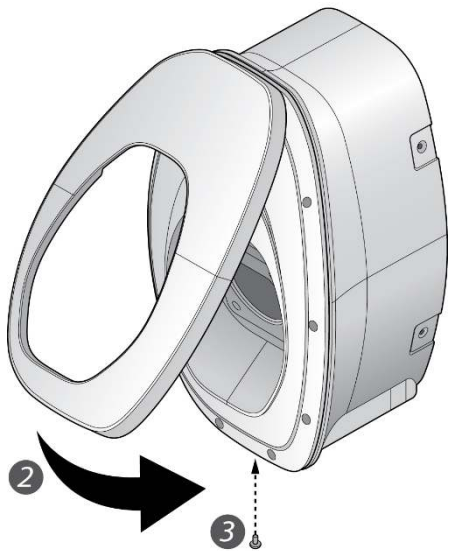

2. Recover the front cover on the EVSE.
3. Secure the screw located at the bottom of front cover by using a Torx T20 screwdriver.

Torque: 0.5 N·m (4.4 lb·in)

---

## 3 Commissioning

AC MAX can use the **Web Configuration Tool** to do the configuration, firmware upgrade, log download, etc.

General process:

1. Finish the installation process and power on the EVSE.
2. Connect to the EVSE with your Laptop or smart phone. If using the Ethernet connection, please finish the connection during installation process.
3. Configure the EVSE based on following instruction, and click the button “Save and Restart Charger” if needed.
4. Start to charge your EV with operating instruction.

### 3.1 Connection setting

#### 3.1.1 Through “Ethernet” connection

1. Click network icon  in the Taskbar. Open “network and internet setting” and choose the connected network.

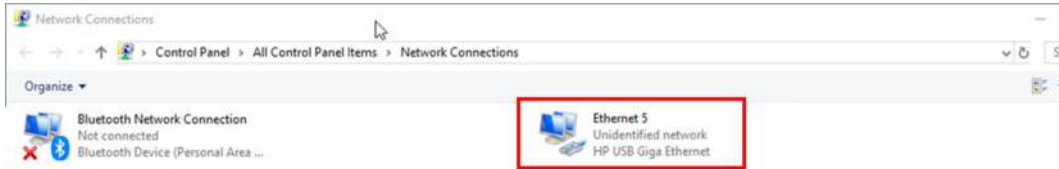

2. Choose TCP/IPv4 and enter the IP address  
 IP address: 192.168.123.101  
 Subnet mask: 255.255.255.0

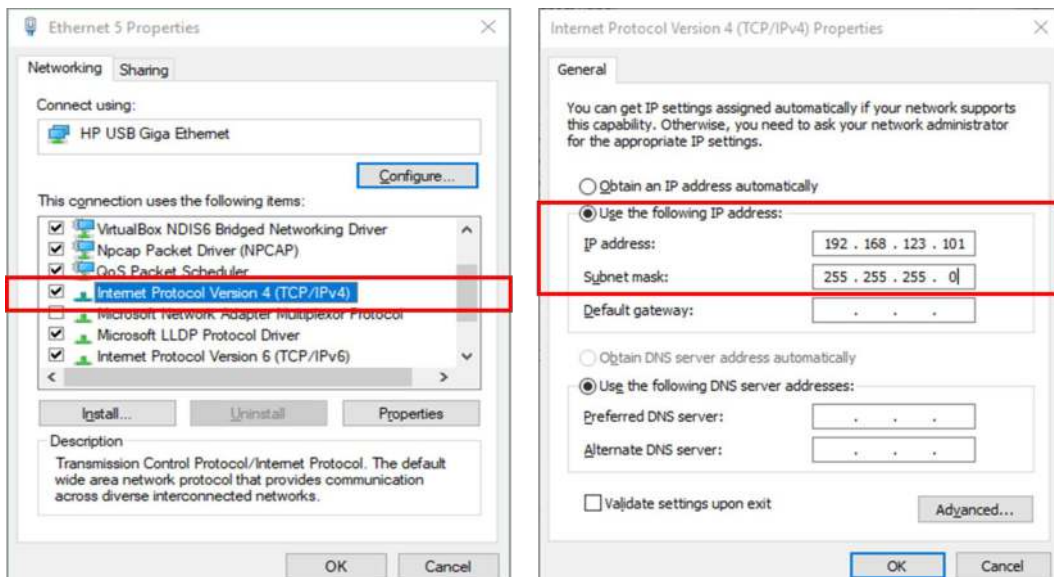

#### 3.1.2 Through “Wifi” connection

1. Click network icon  in the Taskbar. Open “network and internet setting” and choose the connected network.(SSID: Delta-serial number/ Password: please refer to the last page of “Quick Installation Guide”)

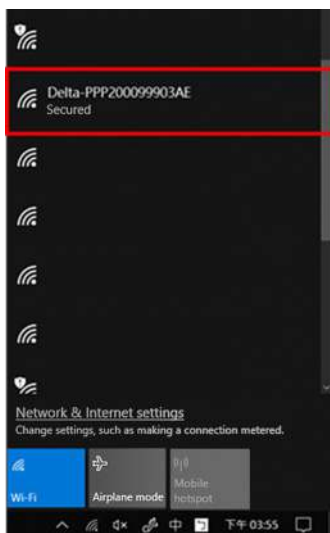

Note: serial number refers to the spec label on EVSE.

## 3.2 Login

1. Open web browser.

Note: recommended web browser includes Chrome 67 and above, safari 11 and above, IE 10 and above, Firefox 61 and above.

2. Enter the web address and login.

Default web address: 192.168.123.123 (Ethernet)/ 192.168.5.1(WiFi)

User account: admin

Password: please refer to the last page of “Quick Installation Guide”



Note: “Failed login attempts” is allowed 5 times and the account will be locked afterwards. User can try it again after 5 minutes.

3. After login, user can see the “Home” page and EVSE information.

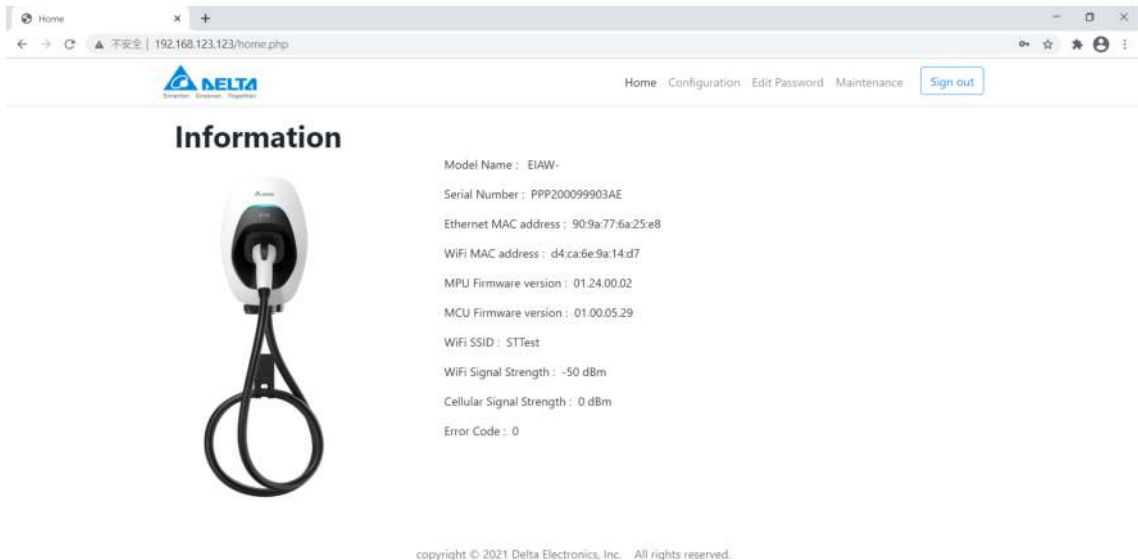



### 3.3 Configuration

#### 3.3.1 Operating without OCPP system

User can configure the below information for EVSE:

Item	Description
Authentication	Choose the authorized mode for user authentication. Default will be “RFID mode”.
Maximum charging time	Choose the maximum charging time for each charging session. Default will be “No limit”.
Maximum charging current	Choose the maximum charging current per phase. It is limited by the dip switch setting.
System time	Choose the system time “YYYY/MM/DD- HH:MM:SS”
Wifi AP mode	When active, EVSE is capable of commissioning through wifi connection directly.

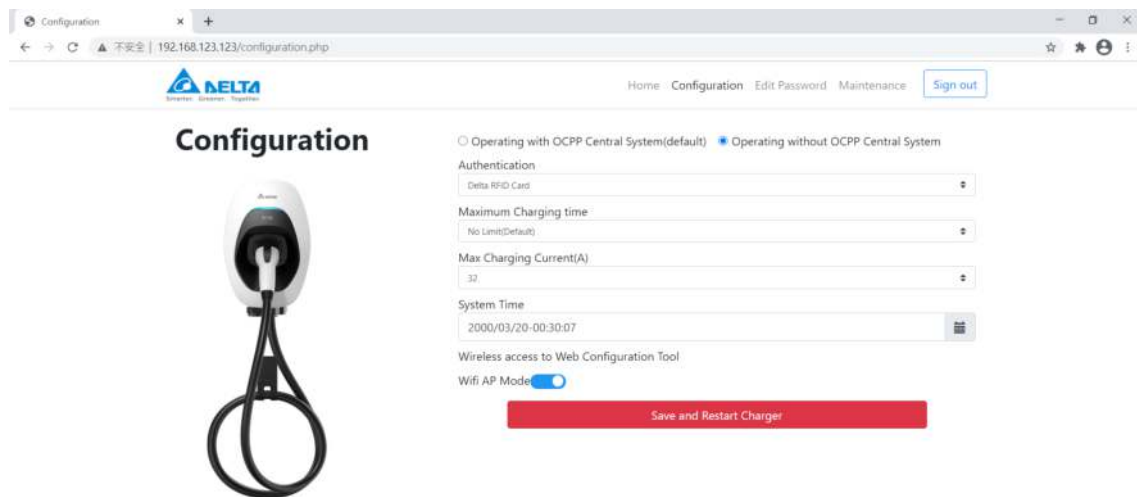

#### 3.3.2 Operating with OCPP system

User can configure the below information for EVSE:

Item	Description
Charge Box ID	The Box ID shall be consistent with the one in your OCPP system.
Server URL	Enter the URL to connect to your OCPP system
OCPP version	Choose OCPP version. Default will be “OCPP 1.6J”.
Offline policy	Choose the behavior when disconnection. Default will be “Local authentication”.
Maximum charging current	Choose the maximum charging current per phase. It is limited by the dip switch setting.
System time	Choose the system time “YYYY/MM/DD- HH:MM:SS”
Wifi AP mode	When active, EVSE is capable of commissioning through wifi connection directly.

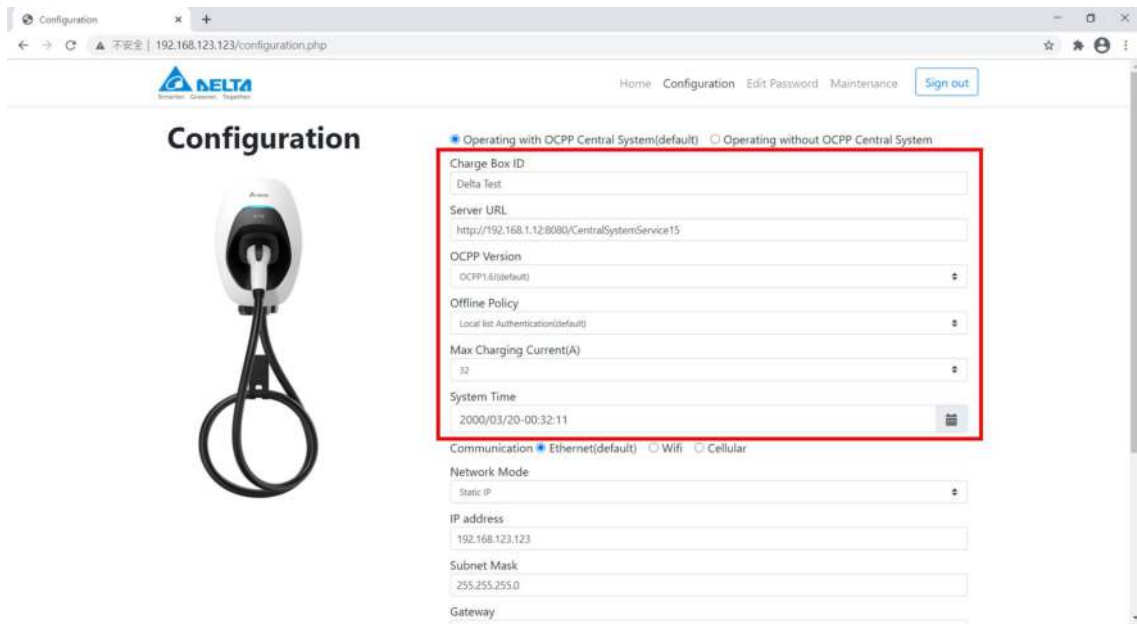

For communication setting, please refer to below section. Users are able to connect the OCPP system through either “Ethernet”, “Wifi”, or “Cellular” connection.

### 3.3.2.1 Connection through “Ethernet”

Choose the “Network mode”, and enter the corresponding information.

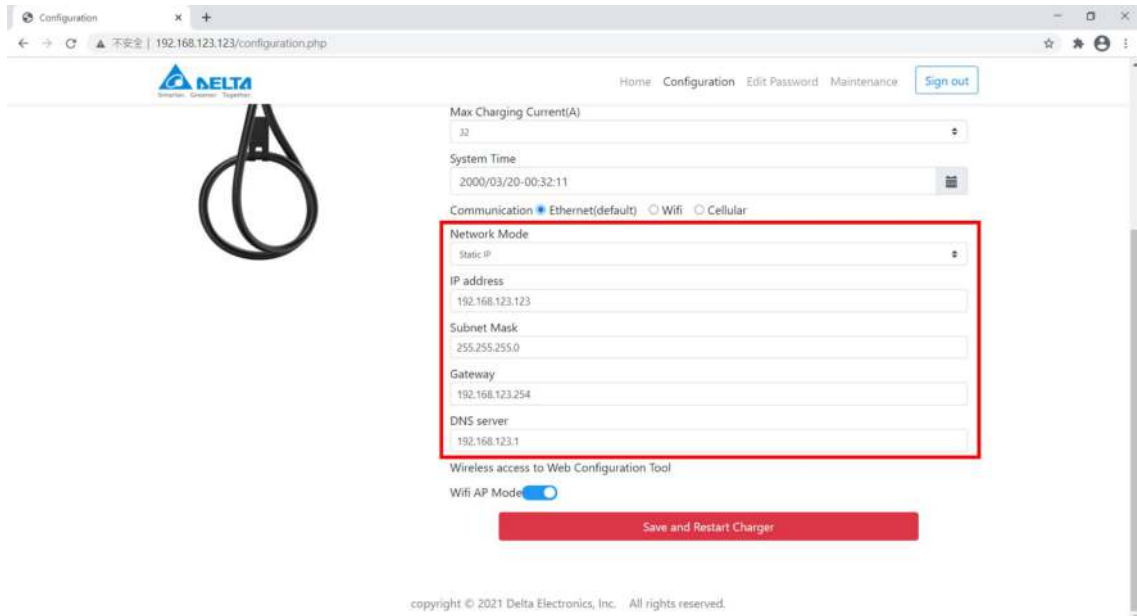

### 3.3.2.2 Connection through “Wifi”

Enter the information based on your wireless AP setting.

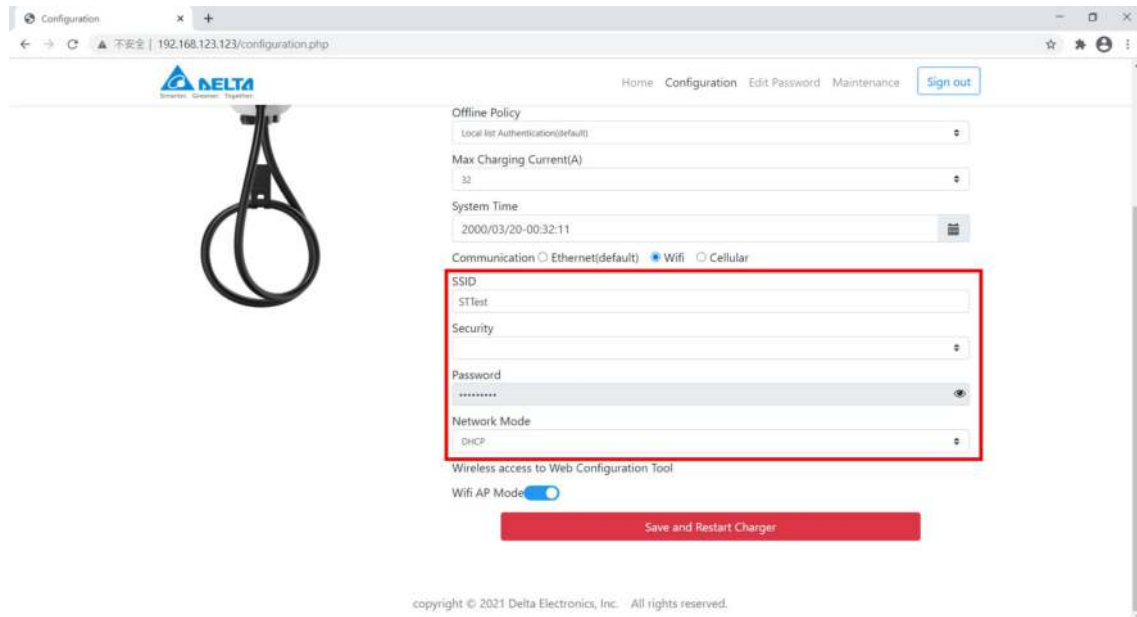

The screenshot shows the Delta configuration web interface for Wifi connection. The browser address bar shows the URL `192.168.123.123/configuration.php`. The page title is "Configuration". The navigation menu includes "Home", "Configuration", "Edit Password", "Maintenance", and "Sign out". The main content area is titled "Offline Policy" and includes the following fields:

- Local list Authentication(default):
- Max Charging Current(A):
- System Time:
- Communication:  Ethernet(default)  Wifi  Cellular
- SSID:
- STTest:
- Security:
- Password:
- Network Mode:

Below the fields, there is a "Wireless access to Web Configuration Tool" section with a "Wifi AP Mode" toggle switch set to "On". A red "Save and Restart Charger" button is located at the bottom of the form. The footer contains the text "copyright © 2021 Delta Electronics, Inc. All rights reserved."

### 3.3.2.3 Connection through “Cellular”

Enter the information based on your contract with telecom operator.

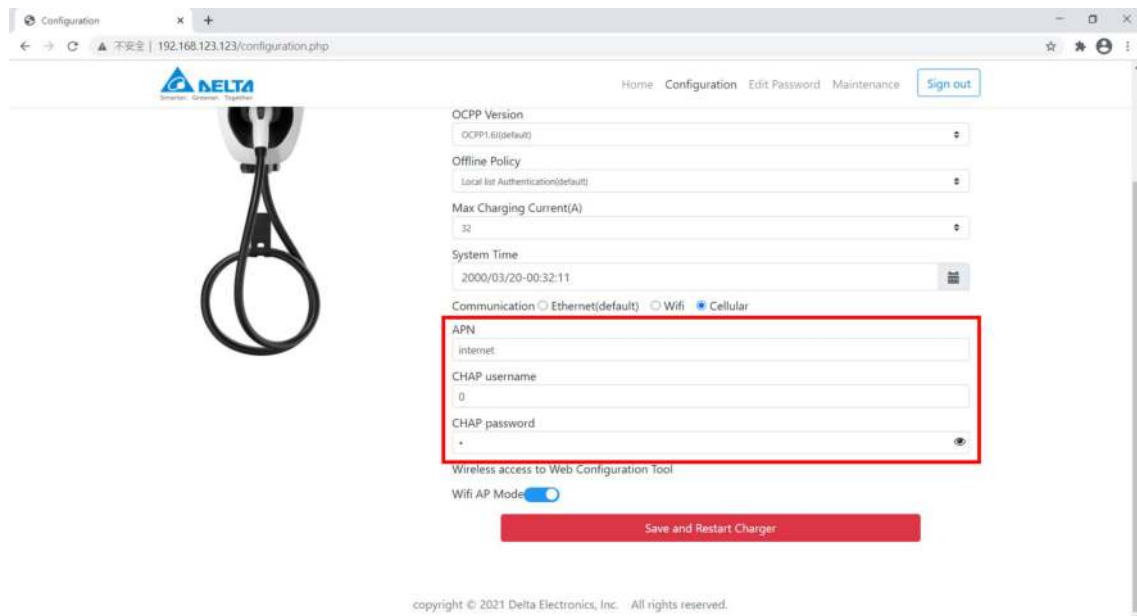

The screenshot shows the Delta configuration web interface for Cellular connection. The browser address bar shows the URL `192.168.123.123/configuration.php`. The page title is "Configuration". The navigation menu includes "Home", "Configuration", "Edit Password", "Maintenance", and "Sign out". The main content area is titled "OCPP Version" and includes the following fields:

- OCPP Version:
- Offline Policy:
- Max Charging Current(A):
- System Time:
- Communication:  Ethernet(default)  Wifi  Cellular
- APN:
- CHAP username:
- CHAP password:

Below the fields, there is a "Wireless access to Web Configuration Tool" section with a "Wifi AP Mode" toggle switch set to "On". A red "Save and Restart Charger" button is located at the bottom of the form. The footer contains the text "copyright © 2021 Delta Electronics, Inc. All rights reserved."

### 3.4 Edit password

User can find default password on quick installation guide, and use it for the setting of new password.

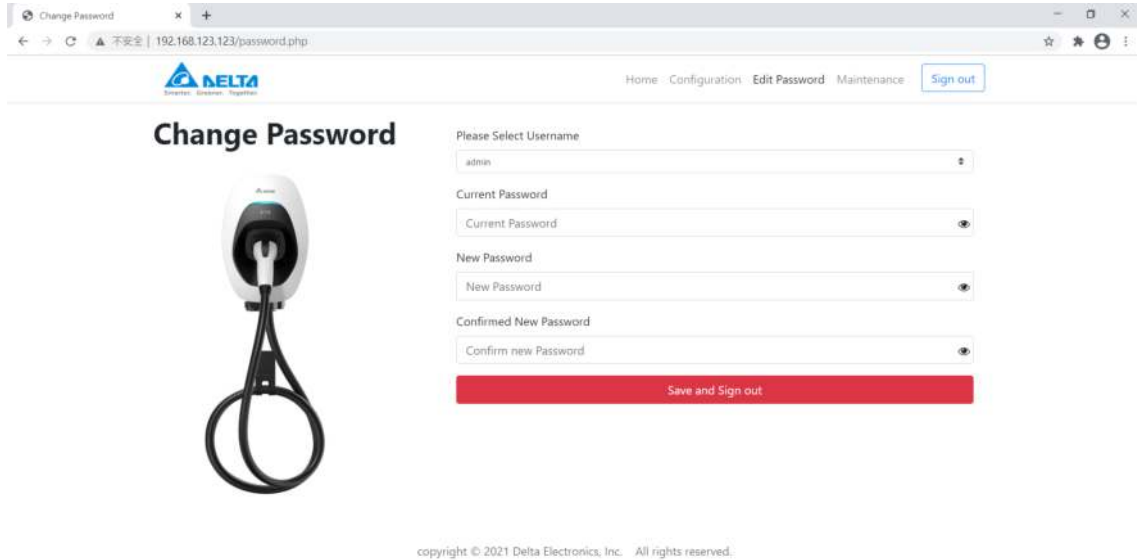

### 3.5 Maintenance

To get the better charging experience, users are recommended to do the maintenance with following instruction:

Item	Description
Firmware update	User can get the latest or improved function through firmware update, and please contact the local dealer or DELTA service partner for the support.
Log download	User can download the log file to analyze the EVSE status.
Factory reset	User can reset the EVSE to default setting.

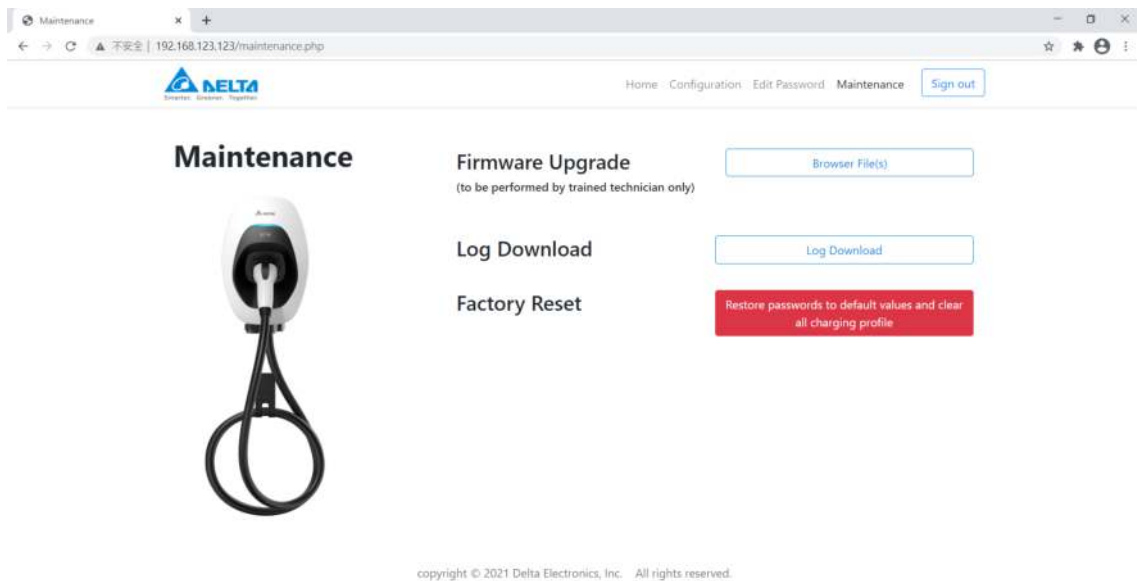

### 3.5.1 Firmware update

1. Press the button "Browser Files(s)".

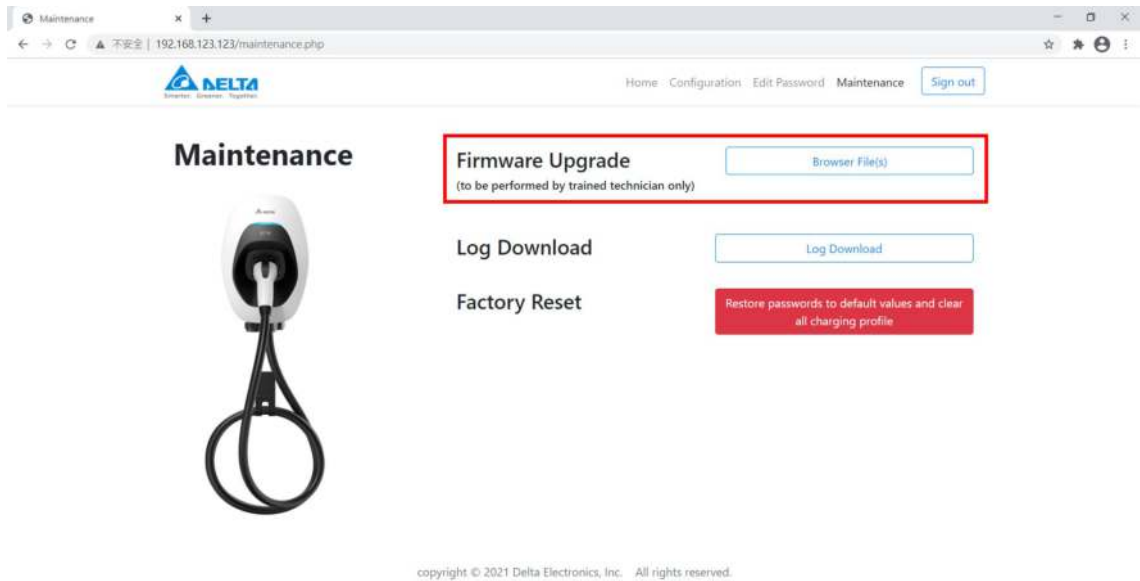

2. Choose the correct path and file to upload.

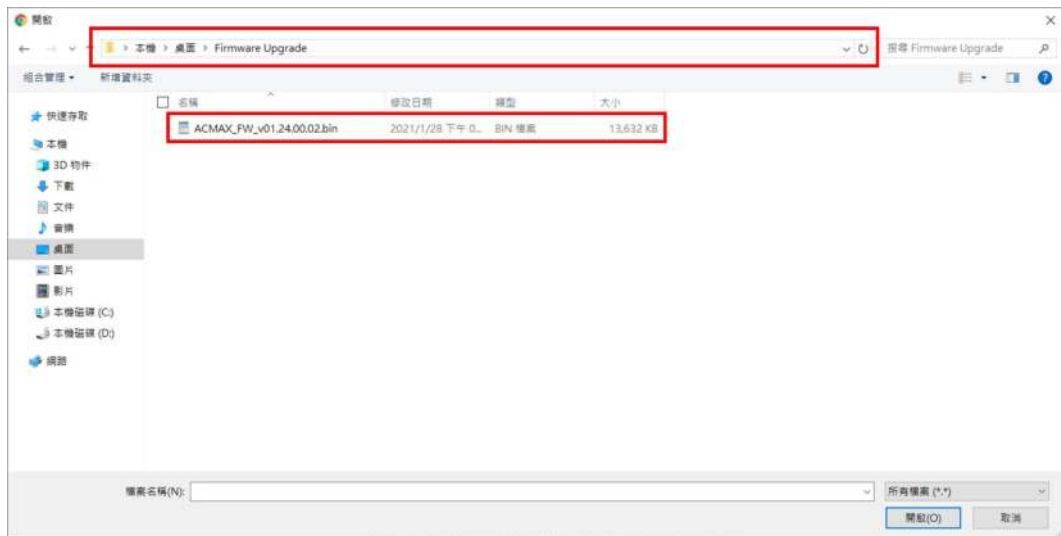

Note: please contact the local dealer or DELTA service partner for the latest firmware file.

3. Press the button "Upload and restart charger" to start uploading.

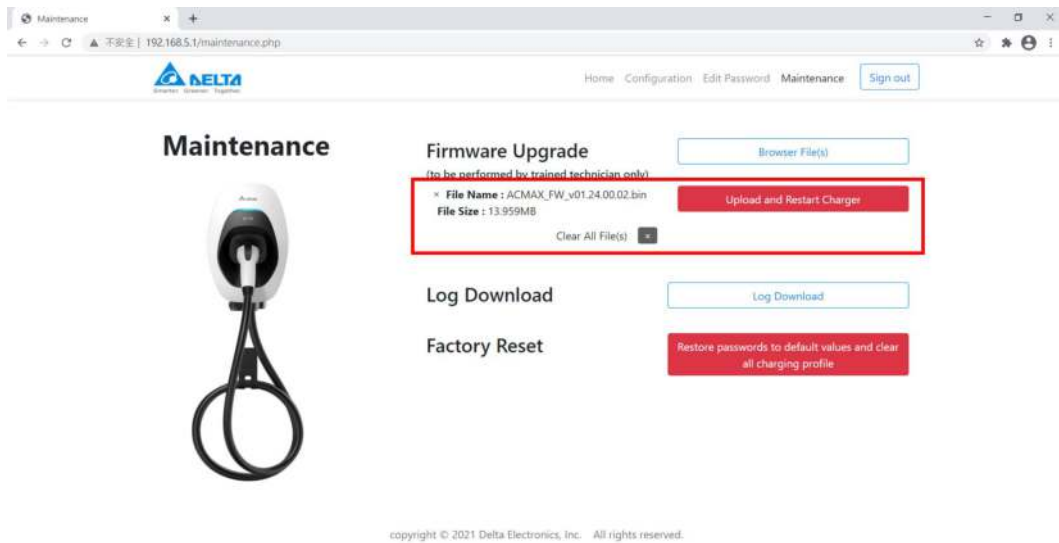

4. Uploading the file.

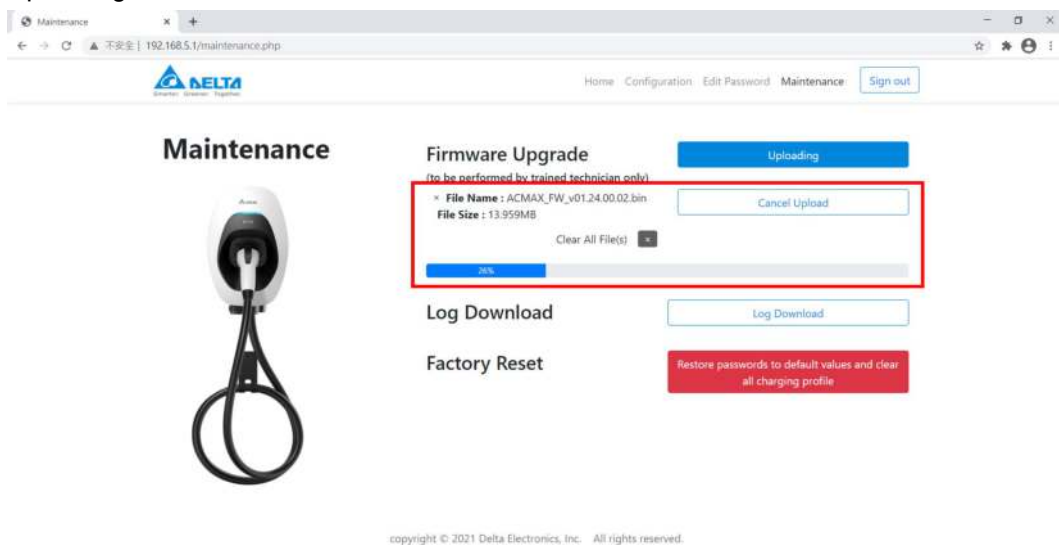

5. After uploading, EVSE will restart automatically.

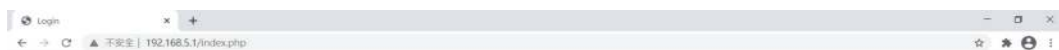

### 3.5.2 Log download

Press the button “Log download” to get the log file.

Note: user may describe your question and copy the file when contacting the local dealer or DELTA service partner.

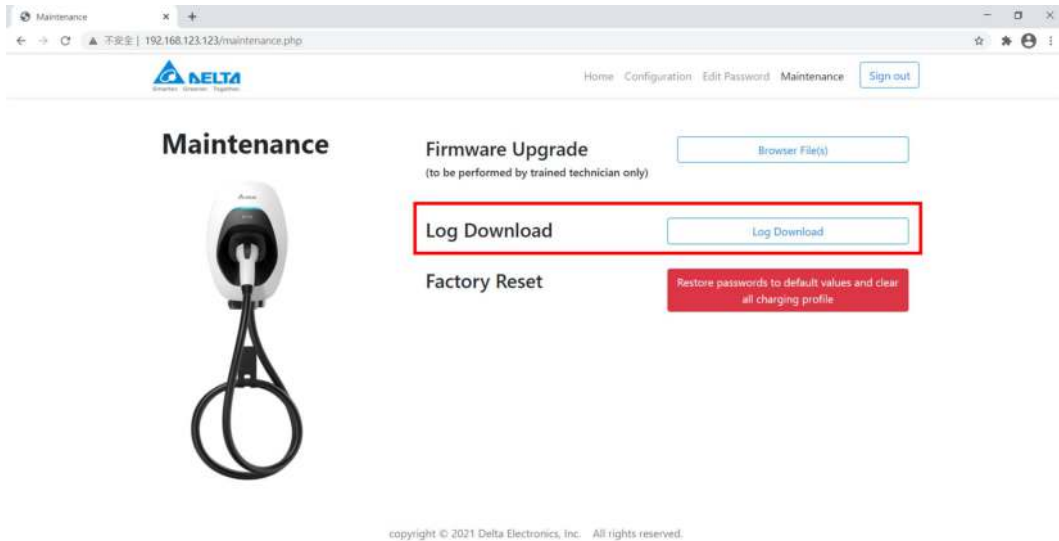

### 3.5.3 Factory reset

User can restore the EVSE to factory setting by pressing the button “Restore passwords to default values and clear all charging profile”.

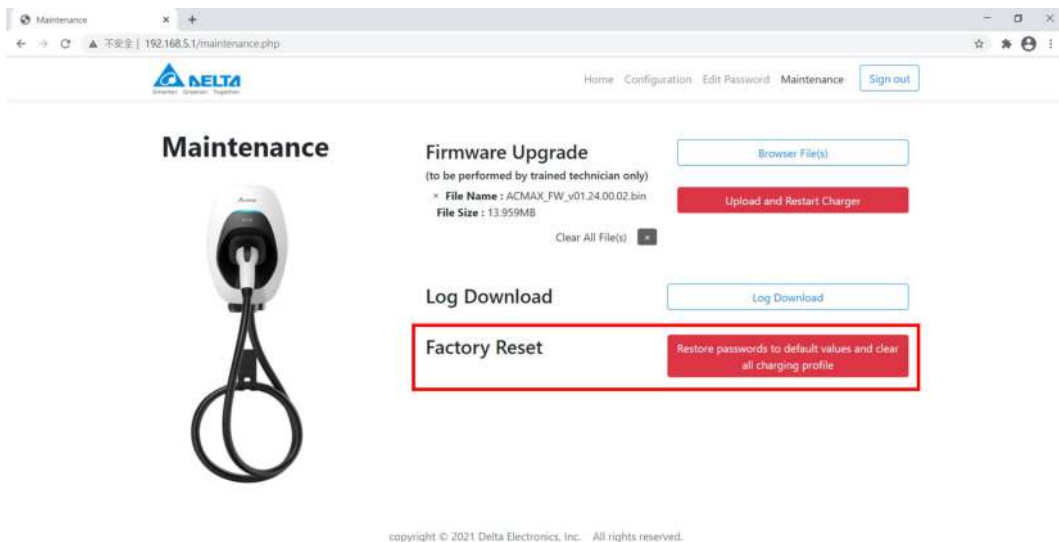

### 3.6 Forgot password

If user forgot the password, please follow below to recover.

1. Click the “Forgot Password.?”.

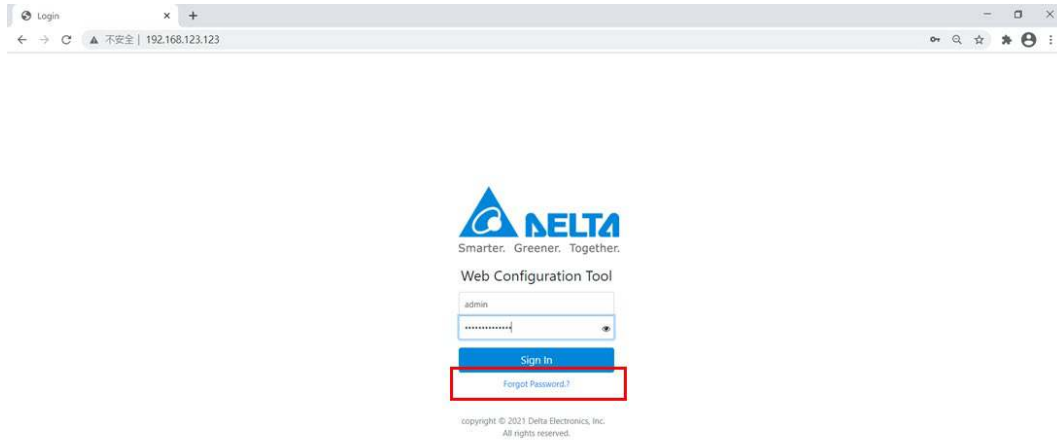

2. Click the button “Restore passwords to default values”

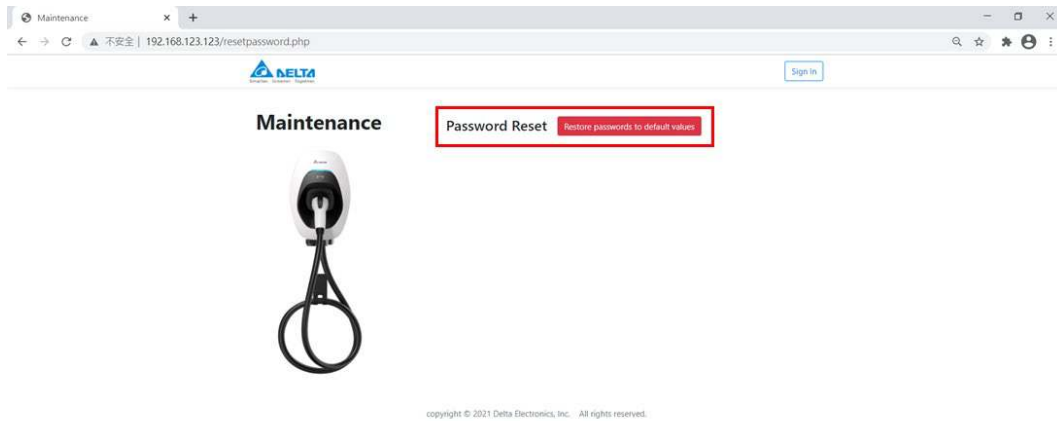

3. Confirm if the user want to reset the password. After clicking the button “Yes”, the EVSE will restart automatically.

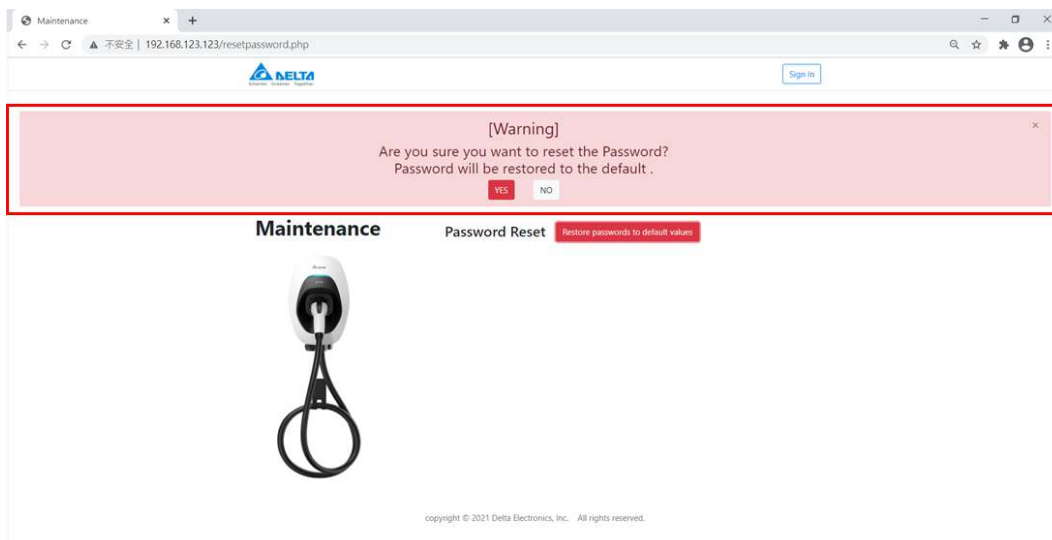



## 4 Operation

Turn on the upstream breaker. The indicator flashes in yellow during a system self-test. After the self-test completed, the indicator illuminates in blue and the EVSE is ready to charge.

### 4.1 Start charging

1. Connect the vehicle connector to vehicle inlet.  
 Note: for socket or socket with shutter model, please connect the plug to EVSE first.
2. Place the RFID card over the sensor area to initiate the charging process.  
 Note:
  - a. Successful card detection is indicated by two short beeps. A long beeping sound indicates authentication failure. Please check your card and try it again.
  - b. The EVSE returns to standby mode if the vehicle connector is not connected to the EV within 60 seconds after card authentication.
3. The indicator flashes blue to indicate the charging is initiated.

### 4.2 Stop charging

1. Stop charging session at the vehicle or swipe the RFID card again to stop the charging process.
2. Disconnect the vehicle connector from the vehicle inlet.  
 Note: the plug would be locked by the EV and please unlock the plug if needed.
3. Recover the vehicle connector to vehicle connector inlet.

## 5 LED Indicator

Status	Description
Black	Power off.
Yellow, fast flashing	Initial configuration and self-test
Blue	Standby mode (not connecting to EV).
Yellow	Ready to charge (connecting to EV).
Blue, slow flashing	Charging in progress.
Green	Charging process completed or network connection success.
Yellow, 1 Flash	Network connection fail.
Yellow, slow flashing	Limited output power by active power control or OCPP command, firmware upgrade or log download.
Red, slow flashing	Refer to fault event.
Red	Failed self-test or general malfunction.

## 5.1 Fault events

Status	Description	Action
Red, 1 Flash	High/under voltage protection	The EVSE will be auto-recovery once the voltage is normal. If not, please restart the EVSE or contact customer support.
Red, 2 Flashes	Ground fault protection.	Check the ground system, and wait for recovery.
Red, 3 Flashes	Ground does not correctly connect to the EVSE.	Check if ground (PE) is well connected.
Red, 4 Flashes	Over current protection.	Unplug the vehicle connector and plug it again.
Red, 5 Flashes	Over temperature protection.	Wait for recovery and check if any heat source around the EVSE. If yes, please try to remove the heat source.
Red, 6 Flashes	Input mis-wired.	Swap the Line (L) and Neutral (N).
Red, 7 Flashes	Control pilot signal error, Gun lock error/fault	Unplug the vehicle connector and plug it again. If not recovery, please contact customer support.

## 5.2 Symbol description

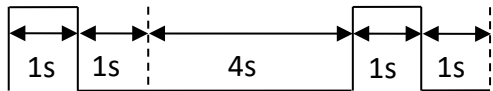
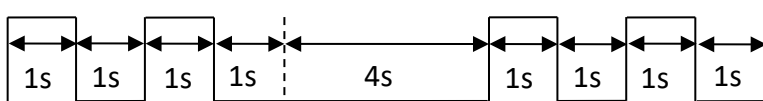
Status	Description
Slow flashing	Slow flashing (period = 2 s, duty cycle = 50%)
Fast flashing	Fast flashing (period = 0.8 s, duty cycle = 50%)
1 Flash	
2 Flashes	
3 or more Flashes refer to previous figures of time duration.	

## 6 Troubleshooting

Contact Customer Support if the EVSE appears to malfunction or if the LED indicators display a fault event. DO NOT open the EVSE, touch or remove the circuit protective devices or any other component.

Situation	Action
Indicator does not light	<ol style="list-style-type: none"> <li>1. Make sure the power input is connected correctly and the power is within operating range of the unit.</li> <li>2. Power cycle the EVSE.</li> <li>3. If the problem persists, contact customer support.</li> </ol>
Indicator does not flash after plugging vehicle connector	<ol style="list-style-type: none"> <li>1. Check if the vehicle connector is fully inserted to EV</li> <li>2. Check if the battery is full on EV</li> <li>3. If the problem persists, contact customer support.</li> </ol>
Indicator starts to flash in red while charging	<ol style="list-style-type: none"> <li>1. Wait until the temporary error is resolved and the EVSE returns to normal condition, typically less than 10 seconds.</li> <li>2. Unplug the vehicle connector.</li> <li>3. Power cycle the EVSE.</li> <li>4. If the situation persists, contact customer support.</li> </ol>
Indicator illuminates in red	<ol style="list-style-type: none"> <li>1. It might be a critical error (e.g. hardware fault).</li> <li>2. Unplug the vehicle connector.</li> <li>3. Power cycle the EVSE.</li> <li>4. If the situation persists, contact customer support.</li> </ol>

## 7 Specifications

Version	Smart
Charging mode	Mode 3
Charging interface	IEC 62196-2: Type 1 plug, Type 2 plug, Type 2 socket, or Type 2 socket with shutter
Input/output rating	220-240 Vac, single phase, 16 A or 32 A max., 50-60 Hz 380-415 Vac, three phase, 16 A or 32 A max., 50-60 Hz
Input wiring	Single phase: L1, N, PE Three phase: L1, L2, L3, N, PE/ L1, L2, L3, PE (IT)
Grounding system	TT/TN/IT
Standby power	< 5 W*
Altitude	2000 m
Internal residual current detection	AC 30 mA, DC 6 mA (Follow IEC 62955 regulation "provided the automatic test function is performed at every switch on and at intervals once a day")
Surge protection	Class II
Electrical protection	Over current protection, short circuit protection, over voltage protection, under voltage protection, ground fault protection, surge protection, over temperature protection
Cold load pick-up	Randomized delay between 5 and 100 seconds before the charge resume after power outages.
Status indicators	Blue, green, red, yellow
Network interface	Bluetooth, Ethernet, wifi or cellular
Charging protocol	OCPP 1.6J
Card reader	RFID card reader compliant to ISO/IEC 14443 A/B
Operating temperature	-30°C to +50°C ( -22°F to +122°F)
Storage temperature	-40°C to +80°C (-40°F to +176°F)
Relative humidity	< 95%, non-condensing
Length of charging cable	5 m, straight cable
Ingress protection	IP55
Impact protection	IK09
Cooling	Natural cooling
Dimension (H x W x D)	371 x 218 x 167 mm (14.6 x 8.6 x 6.6 inch), excluding charging cable, mounting bracket and cable holder
Net weight	3.9 kg*
Compliance/ certificate	CE, UKCA

\*Depends on model configuration

## 8 Cleaning

Regular cleaning of EVSE is required while standby state. Using a soft damp cloth with clear water is highly recommended and make sure no water enters the vehicle connector.

## 9 Warranty

Customer service can provide more information on the terms of warranty. However, the following cases are not covered by the warranty.

- Defects or damage caused by not using the product as specified in the Installation and Operation Manual.
- Costs and damage caused by repair work which is not provided by DELTA approved authorized specialist or electrician.

## 10 Disposal

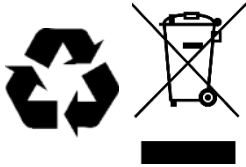

The EVSE is an electronic device and must be disposed of separately from normal house wastes. Please have it disposed in compliance with the waste disposal and recycle local regulation.