

TECHNICAL DATA

MODEL BA101-E3

SUPREME HEAVY DUTY

Automatic Hand Dryer 2kW

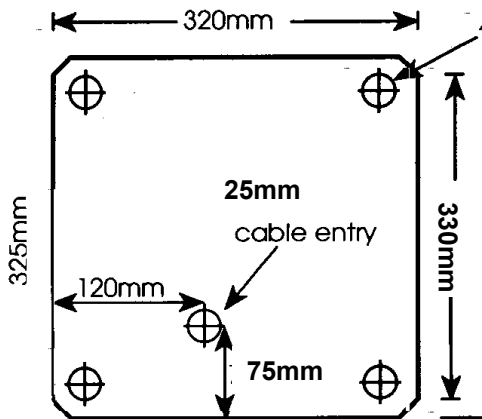
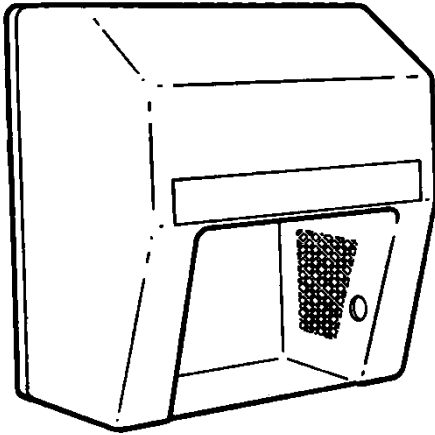

Height recommendations

Recommended height to bottom of dryer.		
Men's washroom		1100mm
Ladies' washroom		1050mm
Children's washroom	13-17yrs	1000mm
Children's washroom	10-13yrs	950mm
Children's washroom	7-10yrs	900mm
Children's washroom	4-7yrs	800mm
Disabled Person's		950mm

Motor	190W, 6670rpm, tropic proofed.
Sound levels	65DB (A) @1.5m
Fan	Glass reinforced nylon flame retardant Injection moulded, delivery 4.25 cubic meters air per minute.
Element	2.0kW, heavy duty, protected by a resettable cut-out at 95C and thermal fuse
Rating	9.8amps, @ 240VAC. IP22
Start-stop	Electronic, infrared sensor
Cover	ABS/ Polycarbonate blend—white
Dimensions	320mm wide x 325mm high x 190mm deep
Weight	3.8kg approx
Warranty	Supreme 24 month limited warranty
Standards	IEC 60335-2-23, AS/NZ 3350.2.23 1997 BS EN 60335-2-23 1997 CISPR 14-1 2000.

SAMPLE SPECIFICATION

Supreme BA101 automatic hand dryer

General

Scope:- Supply and install Supreme BA101 automatic hand dryer as shown on the plans

Materials

Primary Materials:- Supreme BA101 electrical automatic hand dryer complete with white ABS/ Polycarbonate cover

Workmanship

Remove Hand Dryer cover:- remove 2 x 6mm screws on the underside of the dryer. Lift lower part of the cover forward approximately 12mm then push cover upwards to unlatch top of cover from back plate. Position back plate on the wall with 320mm width to the top and height 325mm to the left side as you face the dryer.

Washrooms Mount at recommended height from floor varies, refer chart opposite

Fasten dryer to the wall using 4 only wood screws or 6mm toggle bolts for steel framed walls or 6mm masonry anchors for masonry walls.

Electrical connection to be made by hard wiring back to isolating switch mounted in a convenient position in accordance with Electrical Codes of Practice.

Plug sensor leads from cover to printed circuit board. Replace cover, latch top of cover onto back plate, ease bottom of cover into place and then replace the 2 only 6mm screws.

Completion

Leave work clean, remove all trade rubbish from the site and leave the hand dryer cleaned and in working order.

Pass over warranties/manuals (supplies 24 months material and workmanship guarantee) to the principal. Give maintenance instructions to principal.



P.O Box427, Cambridge,
New Zealand
Tel: 64 7 823 5790 | Fax: 64 7
823 5792
office@splwashrooms.co.nz
www.splwashrooms.co.nz

We reserve the right to alter specifications and design without prior notice