

## BUSBAR SUPPORTS

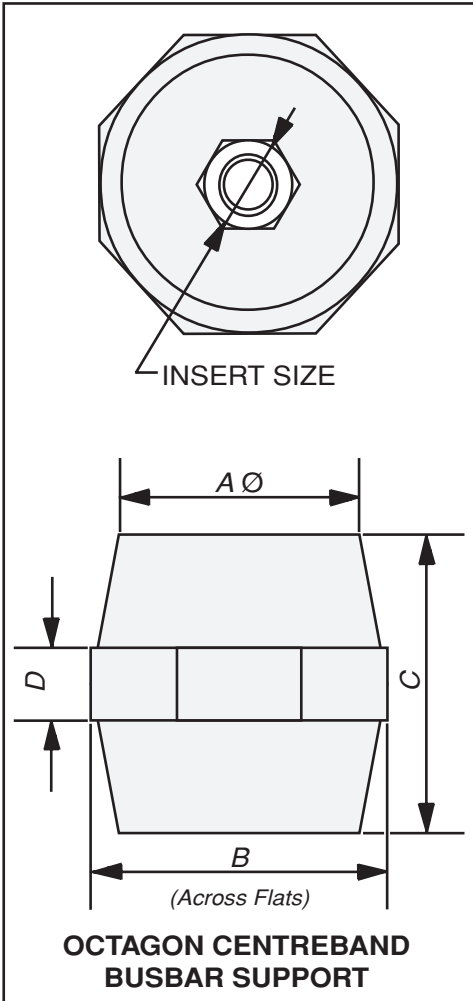

Crompton Greaves manufactures a range of busbar supports with octagonal centreband to compliment their range of switchboard and control panel accessories.

These insulators are moulded from high electrical grade, red Polyester Reinforced Resins (DMC), fitted with brass inserts and are offered at very competitive prices with no compromise of quality.



### TECHNICAL SPECIFICATIONS

| Properties        | Unit                             | Test Method          | Value            |
|-------------------|----------------------------------|----------------------|------------------|
|                   |                                  |                      | DMC              |
| <b>PHYSICAL</b>   |                                  |                      |                  |
| 1                 | Specific Gravity                 | g/cc                 | 1.80             |
| 2                 | Glass Content                    | %                    | 20               |
| 3                 | Water Absorption                 | %                    | 0.20             |
| <b>MECHANICAL</b> |                                  |                      |                  |
| 1                 | Tensile Strength                 | kg/cm <sup>2</sup>   | BS 2782<br>1200  |
| 2                 | Flexural/Cross Breaking Strength | kg/cm <sup>2</sup>   | BS 2782<br>550   |
| 3                 | Compressive Strength             | kg/cm <sup>2</sup>   | BS 2782<br>1450  |
| 4                 | Impact Strength - Izod           | kgcm/cm <sup>2</sup> | BS 2782<br>35    |
| <b>ELECTRICAL</b> |                                  |                      |                  |
| 1                 | Dielectric Strength              | kV/mm                | BS 2782<br>13    |
| 2                 | Tracking Index                   | Volts                | BS 5901<br>1000  |
| 3                 | Arc Resistance                   | Secs                 | BS 2782<br>220   |
| 4                 | Heat Distortion                  | °C                   | DIN 53458<br>150 |
| 5                 | Flammability                     |                      | ASTM D495<br>SE  |

### DIMENSIONAL DETAILS

| OCTAGON CENTREBAND BUSBAR SUPPORTS |     |    |    |    |        |
|------------------------------------|-----|----|----|----|--------|
| PART NO.                           | Ø A | B  | C  | D  | INSERT |
| IO 30 EN                           | 25  | 32 | 30 | 8  | M6     |
| IO 35 EN                           | 25  | 32 | 35 | 9  | M6     |
| IO 35 FN                           | 25  | 32 | 35 | 9  | M8     |
| IO 38 GN                           | 35  | 40 | 38 | 10 | M10    |
| IO 40 EN                           | 35  | 40 | 40 | 10 | M6     |
| IO 40 FN                           | 35  | 40 | 40 | 10 | M8     |
| IO 50 FN                           | 31  | 41 | 50 | 10 | M8     |
| IO 50 GN                           | 31  | 41 | 50 | 10 | M10    |
| IO 50 HN                           | 31  | 41 | 50 | 10 | M12    |
| IO 60 GN                           | 40  | 55 | 60 | 11 | M10    |
| IO 60 HN                           | 40  | 55 | 60 | 11 | M12    |